



# Preisliste 2025

**LIVARSA GmbH**

gültig ab 02/2025

[www.LIVARSA.com](http://www.LIVARSA.com)

# Elektrischer Effizienzfilter *System 400*

## Ohne Leistungsschalter

Artikel-Nr.	Filter	Leistungsschalter	Maße B/H/T	Gewicht	Icw Filter	Icu Schalter	Listenpreis o. MWSt.
EF040_L040	400A	ohne	910/1860/760 mm	530 kg	15kA	---	33.359,-- €
EF040_L063	400A	ohne	910/1860/760 mm	550 kg	15kA	---	35.169,-- €

## Mit Leistungsschalter

Artikel-Nr.	Filter	Leistungsschalter	Maße B/H/T	Gewicht	Icw Filter	Icu Schalter	Listenpreis o. MWSt.
EF040_L040_40_1	400A	1 x LS 400A	910/1860/760 mm	580 kg	15kA	36kA	36.617,-- €
EF040_L063_63_1	400A	1 x LS 630A	910/1860/760 mm	600 kg	15kA	36kA	39.332,-- €

### Filter Belastung

263 kW / 400A	Bleibt der Filter zugeschaltet (Wirkung)	geht nach dieser Zeit in den BYPASS
276 kW / 420A		
289 kW / 440A		
302 kW / 460A	45 min	
316 kW / 480A	12 min	
329 kW / 500A	5 min	
342 kW / 520A	2 min 50 sec	
362 kW / 550A	1 min 30 sec	
394 kW / 600A	42 sec	
414 kW / 630A	30 sec	



## Ohne Leistungsschalter

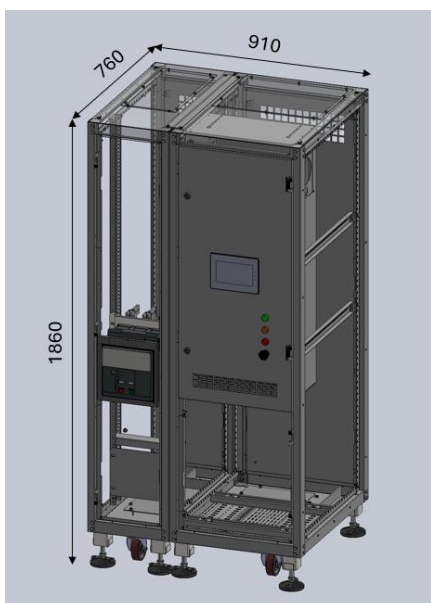

## Mit Leistungsschalter

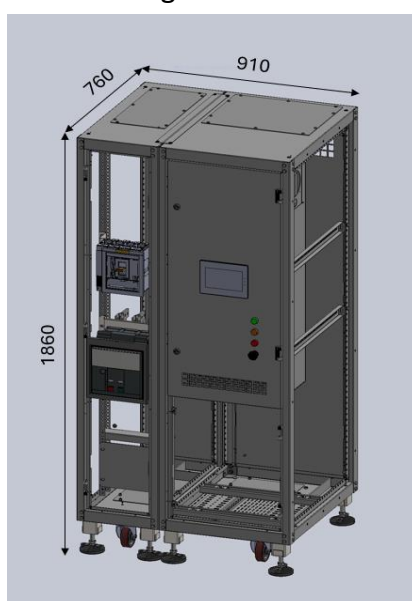

# Elektrischer Effizienzfilter *System 600\_1*

Mit 1 Leistungsschalter

Artikel-Nr.	Filter	Leistungsschalter	Maße B/H/T	Gewicht	Icw Filter	Icu Schalter	Listenpreis o. MWSt.
EF060_L060_10_1	600A	1 x LS 1000A	1150/1860/860 mm	700 kg	32kA	50kA	48.291,-- €
EF060_L080_10_1	600A	1 x LS 1000A	1150/1860/860 mm	720 kg	32kA	50kA	50.554,-- €
EF060_L091_10_1	600A	1 x LS 1000A	1150/1860/860 mm	740 kg	32kA	50kA	54.056,-- €

## Leistungsebene 600A-950A

Filter Belastung		Bleibt der Filter zugeschaltet (Wirkung)	geht nach dieser Zeit in den BYPASS
394 kW / 600A			
421 kW / 640A			
434 kW / 660A			
447 kW / 680A	<b>1 Std 41 min</b>		
460 kW / 700A	<b>25 min</b>		
473 kW / 720A	<b>11 min</b>		
486 kW / 740A	<b>6 min</b>		
493 kW / 750A	<b>5 min</b>		
526 kW / 800A	<b>2 min</b>		
559 kW / 850A	<b>1 min</b>		
592 kW / 900A	<b>42 sec</b>		
625 kW / 950A	<b>29 sec</b>		

Mit einem Leistungsschalter

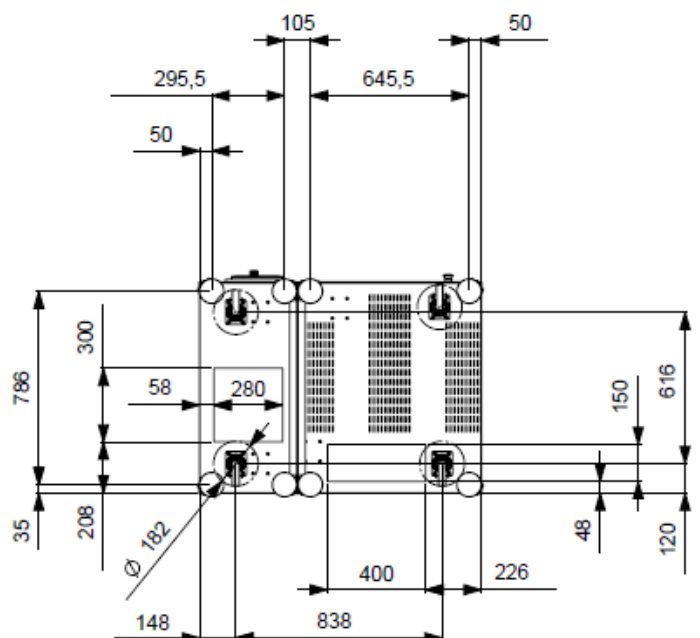
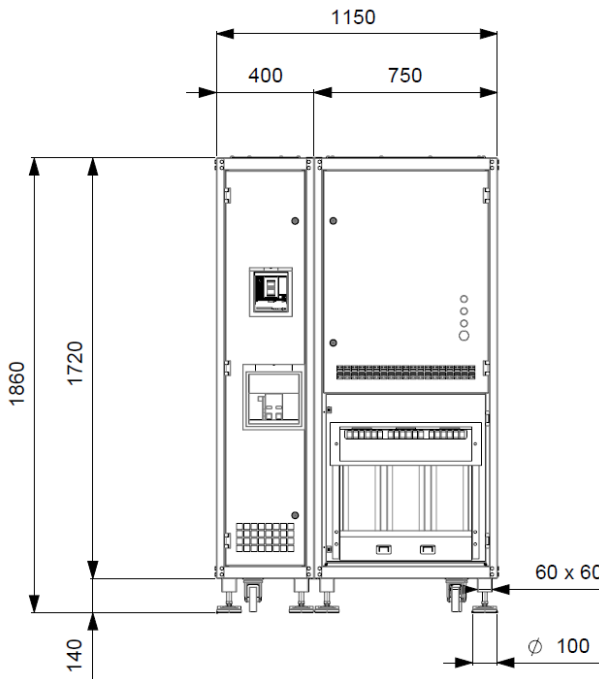
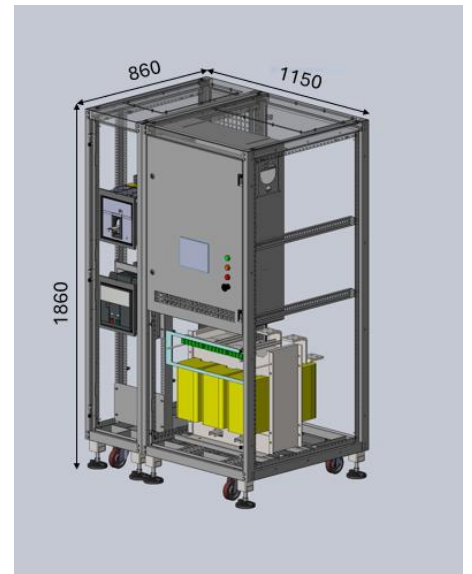

# Elektrischer Effizienzfilter *System 600\_2*

Mit 2 Leistungsschaltern

Artikel-Nr.	Filter	Leistungsschalter	Maße B/H/T	Gewicht	Icw Filter	Icu Schalter	Listenpreis o. MWSt.
EF060_L060_10_2	600A	2 x LS 1000A	1550/1860/860 mm	800 kg	32kA	50kA	57.327,-- €
EF060_L080_10_2	600A	2 x LS 1000A	1550/1860/860 mm	820 kg	32kA	50kA	59.589,-- €
EF060_L091_10_2	600A	2 x LS 1000A	1550/1860/860 mm	840 kg	32kA	50kA	63.997,-- €

Leistungsebene **600A-950A**

Filter Belastung		Bleibt der Filter zugeschaltet (Wirkung)	geht nach dieser Zeit in den BYPASS
394 kW / 600A			
421 kW / 640A			
434 kW / 660A			
447 kW / 680A	<b>1 Std 41 min</b>		
460 kW / 700A	<b>25 min</b>		
473 kW / 720A	<b>11 min</b>		
486 kW / 740A	<b>6 min</b>		
493 kW / 750A	<b>5 min</b>		
526 kW / 800A	<b>2 min</b>		
559 kW / 850A	<b>1 min</b>		
592 kW / 900A	<b>42 sec</b>		
625 kW / 950A	<b>29 sec</b>		

Mit **zwei** Leistungsschaltern

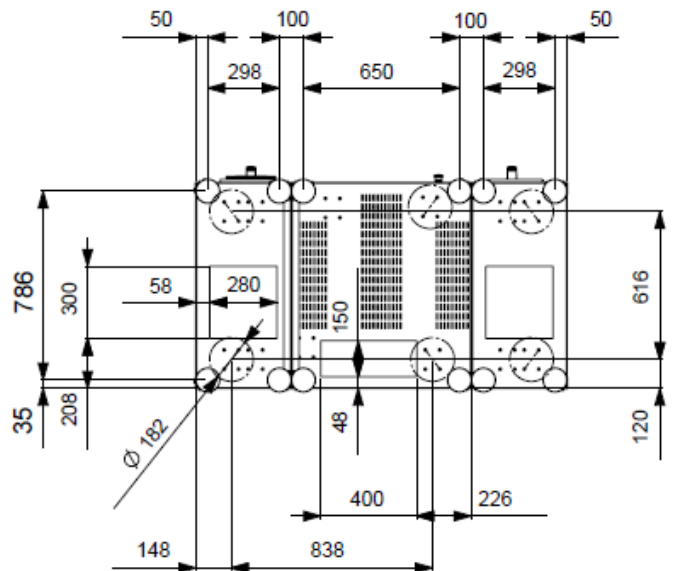
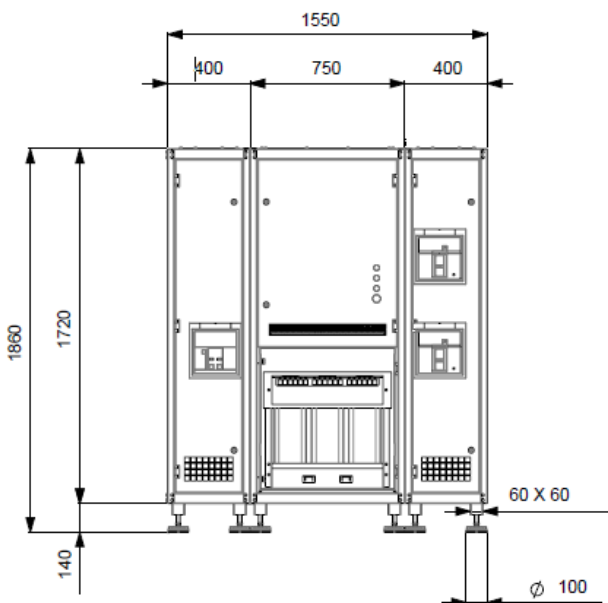
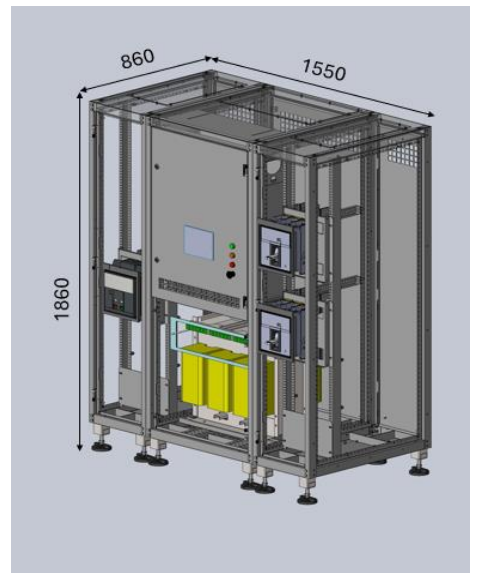

# Elektrischer Effizienzfilter *System 800\_1*

Mit 1 Leistungsschalter

Artikel-Nr.	Filter	Leistungsschalter	Maße B/H/T	Gewicht	Icw Filter	Icu Schalter	Listenpreis o. MWSt.
EF080_L085_16_1	800A	1 x LS 1600A	1150/1860/860 mm	720 kg	36kA	50kA	51.381,-- €
EF080_L100_16_1	800A	1 x LS 1600A	1150/1860/860 mm	740 kg	36kA	50kA	55.182,-- €
EF080_L120_16_1	800A	1 x LS 1600A	1150/1860/860 mm	760 kg	36kA	50kA	60.250,-- €

Leistungsebene **800A-1200A**

Filter Belastung		Bleibt der Filter zugeschaltet (Wirkung)	geht nach dieser Zeit in den BYPASS
526 kW / 800A			
552 kW / 840A			
579 kW / 880A			
592 kW / 900A		<b>3 Std</b>	
605 kW / 920A		<b>45 min</b>	
618 kW / 940A		<b>20 min</b>	
631 kW / 960A		<b>11 min</b>	
657 kW / 1000A		<b>5 min</b>	
690 kW / 1050A		<b>2 min</b>	
723 kW / 1100A		<b>1 min</b>	
756 kW / 1150A		<b>59 sec</b>	
789 kW / 1200A		<b>42 sec</b>	

Mit **einem** Leistungsschalter

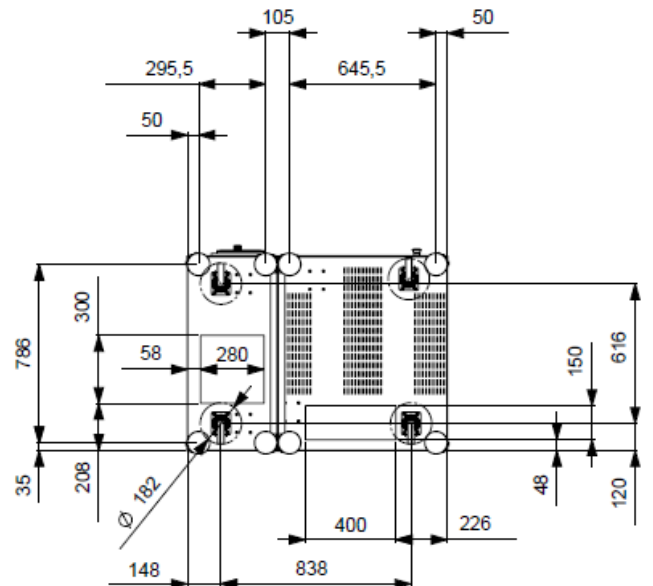
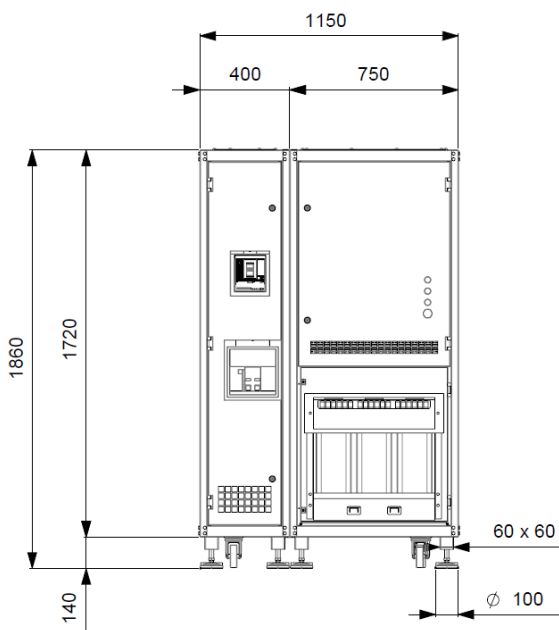
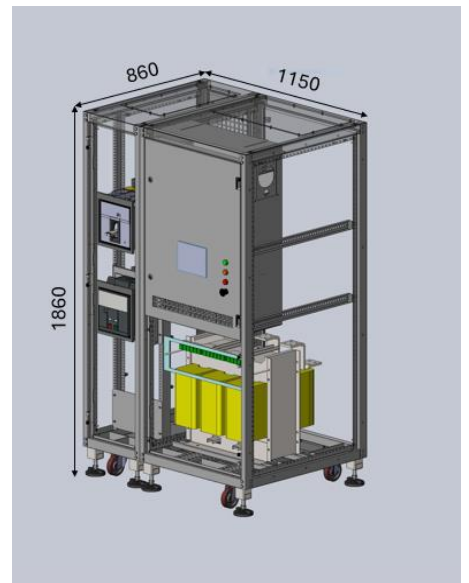

# Elektrischer Effizienzfilter *System 800\_2*

Mit **2** Leistungsschaltern

Artikel-Nr.	Filter	Leistungsschalter	Maße B/H/T	Gewicht	Icw Filter	Icu Schalter	Listenpreis o. MWSt.
EF080_L085_16_2	800A	2 x LS 1600A	1550/1860/860 mm	840 kg	36kA	50kA	60.867,-- €
EF080_L100_16_2	800A	2 x LS 1600A	1550/1860/860 mm	860 kg	36kA	50kA	65.260,-- €
EF080_L120_16_2	800A	2 x LS 1600A	1550/1860/860 mm	880 kg	36kA	50kA	70.920,-- €

## Leistungsebene **800A-1200A**

Filter Belastung		Bleibt der Filter zugeschaltet (Wirkung)	geht nach dieser Zeit in den BYPASS	
526 kW / 800A				
552 kW / 840A				
579 kW / 880A				
592 kW / 900A	<b>3 Std</b>			
605 kW / 920A	<b>45 min</b>			
618 kW / 940A	<b>20 min</b>			
631 kW / 960A	<b>11 min</b>			
657 kW / 1000A	<b>5 min</b>			
690 kW / 1050A	<b>2 min</b>			
723 kW / 1100A	<b>1 min</b>			
756 kW / 1150A	<b>59 sec</b>			
789 kW / 1200A	<b>42 sec</b>			

Mit **zwei** Leistungsschaltern

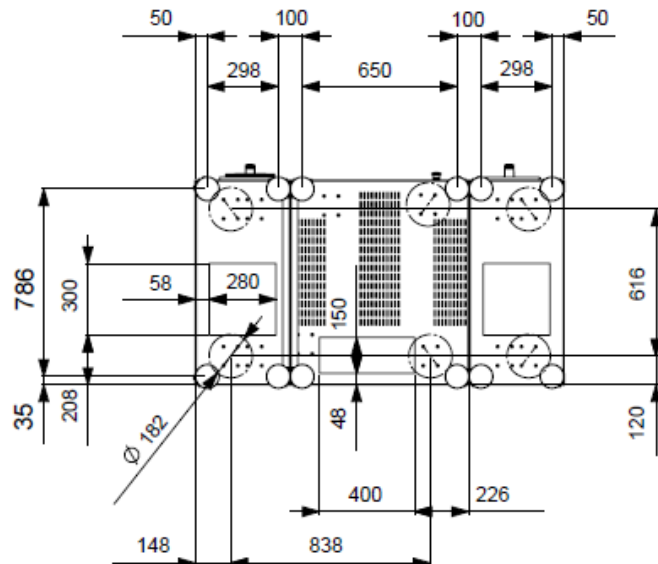
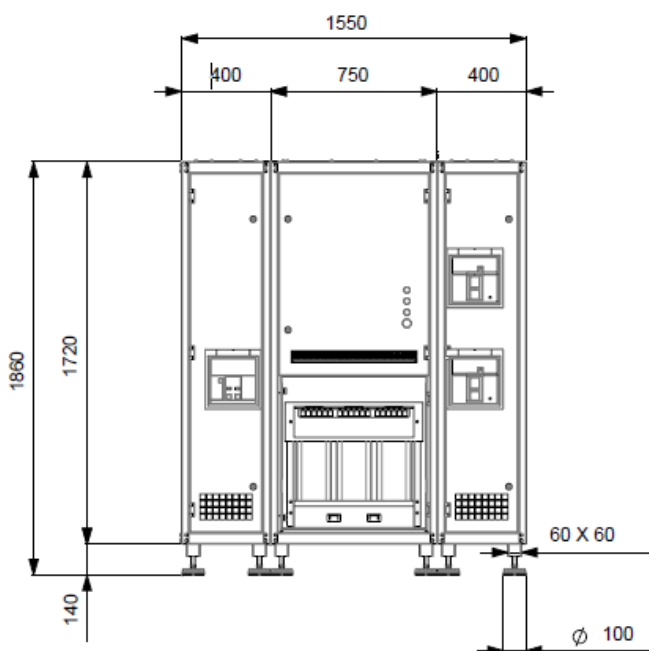
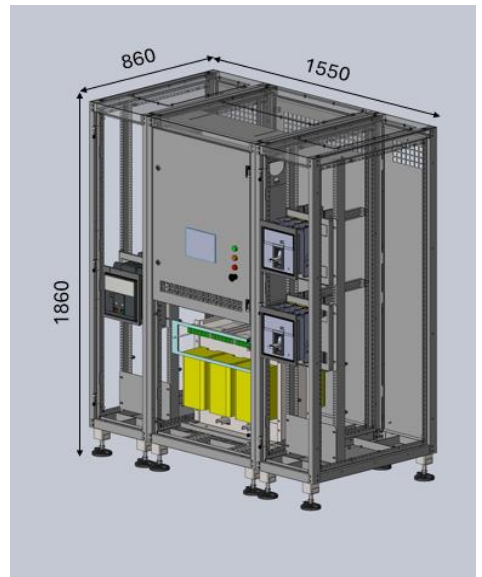

# Elektrischer Effizienzfilter *System 1000\_1*

## Mit 1 Leistungsschalter

Artikel-Nr.	Filter	Leistungsschalter	Maße B/H/T	Gewicht	Icw Filter	Icu Schalter	Listenpreis o. MWSt.
EF100_L125_16_1	1000A	1 x LS 1600A	1410/1960/860 mm	900 kg	50kA	50kA	68.539,-- €
EF100_L160_16_1	1000A	1 x LS 1600A	1410/1960/860 mm	940 kg	50kA	50kA	76.648,-- €

## Leistungsebene 1000A-1600A

Filter Belastung		Bleibt der Filter zugeschaltet (Wirkung)	geht nach dieser Zeit in den BYPASS	
657 kW / 1000A				
690 kW / 1050A				
723 kW / 1100A				
736 kW / 1120A	<b>4 Std 41 min</b>			
749 kW / 1140A	<b>1 Std 10 min</b>			
763 kW / 1160A	<b>31 min</b>			
776 kW / 1180A	<b>18 min</b>			
789 kW / 1200A	<b>11 min</b>			
822 kW / 1250A	<b>5 min</b>			
855 kW / 1300A	<b>3 min</b>			
887 kW / 1350A	<b>2 min</b>			
920 kW / 1400A	<b>1 min</b>			
953 kW / 1450A	<b>55 sec</b>			
986 kW / 1500A	<b>42 sec</b>			
1019 kW / 1550A	<b>33 sec</b>			
1052 kW / 1600A	<b>27 sec</b>			

## Mit einem Leistungsschalter

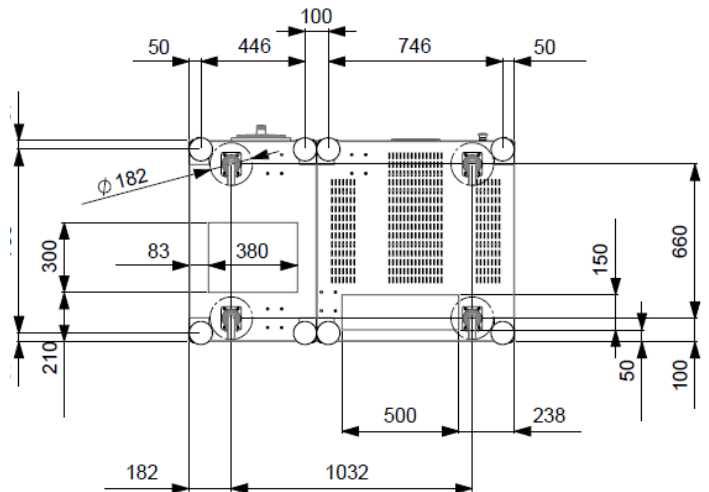
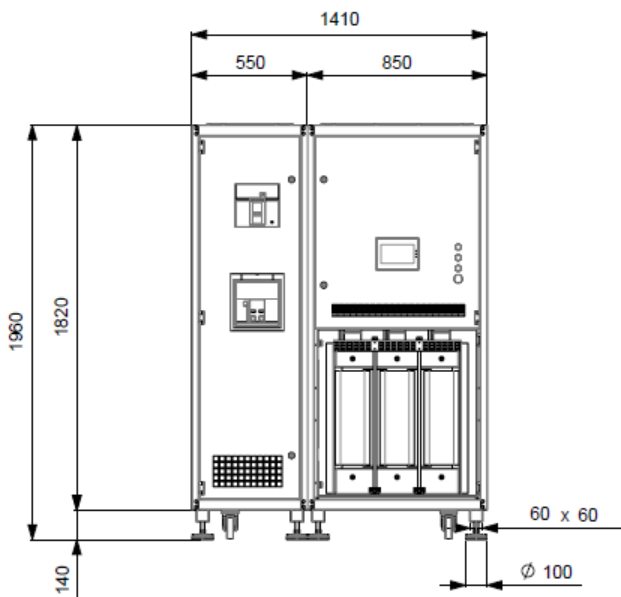

# Elektrischer Effizienzfilter *System 1000\_2*

Mit 2 Leistungsschaltern

Artikel-Nr	Filter	Leistungsschalter	Maße B/H/T	Gewicht	Icw Filter	Icu Schalter	Listenpreis o. MWSt.
EF100_L125_16_2	1000A	2 x LS 1600A	1950/1960/860 mm	1060 kg	50kA	50kA	81.266,-- €
EF100_L160_16_2	1000A	2 x LS 1600A	1950/1960/860 mm	1100 kg	50kA	50kA	90.654,-- €

## Leistungsebene 1000A-1600A

Filter Belastung		
657 kW / 1000A	Bleibt der Filter zugeschaltet (Wirkung)	
690 kW / 1050A		
723 kW / 1100A		
736 kW / 1120A		
749 kW / 1140A	4 Std 41 min	geht nach dieser Zeit in den BYPASS
763 kW / 1160A	1 Std 10 min	
776 kW / 1180A	31 min	
789 kW / 1200A	18 min	
822 kW / 1250A	11 min	
855 kW / 1300A	5 min	
887 kW / 1350A	3 min	
920 kW / 1400A	2 min	
953 kW / 1450A	1 min	
986 kW / 1500A	55 sec	
1019 kW / 1550A	42 sec	
1052 kW / 1600A	33 sec	
	27 sec	

Mit zwei Leistungsschaltern

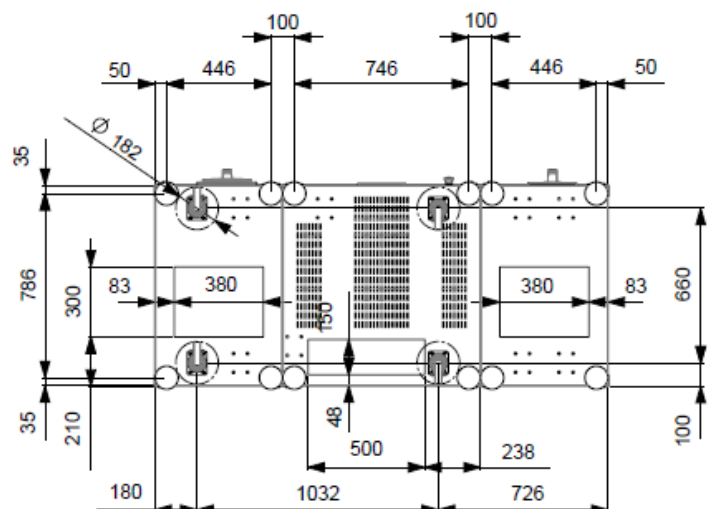
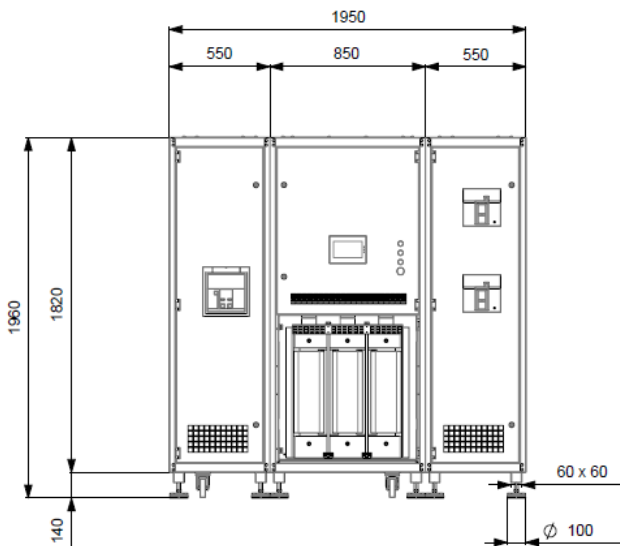
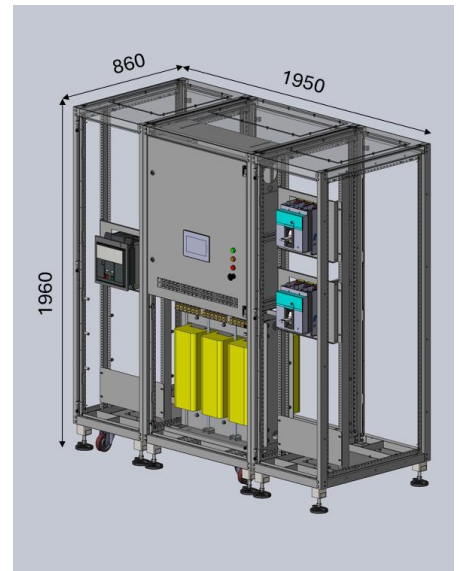



# Elektrischer Effizienzfilter *System 1250\_1*

Mit 1 Leistungsschalter

Artikel-Nr.	Filter	Leistungsschalter	Maße B/H/T	Gewicht	Icw Filter	Icu Schalter	Listenpreis o. MWSt.
EF125_L125_16_1	1250A	1 x LS 1600A	1410/1960/860 mm	1020 kg	50kA	50kA	74.331,-- €
EF125_L160_16_1	1250A	1 x LS 1600A	1410/1960/860 mm	1060 kg	50kA	50kA	82.440,-- €
EF125_L182_20_1	1250A	1 x LS 2000A	1410/1960/860 mm	1100 kg	50kA	42kA	89.781,-- €

## Leistungsebene 1250A-1850A

Filter Belastung		Bleibt der Filter zugeschaltet (Wirkung)	geht nach dieser Zeit in den BYPASS
822 kW / 1250A			
855 kW / 1300A			
887 kW / 1350A			
901 kW / 1370A		<b>7 Std 19 min</b>	
914 kW / 1390A		<b>1 Std 50 min</b>	
927 kW / 1410A		<b>49 min</b>	
940 kW / 1430A		<b>27 min</b>	
953 kW / 1450A		<b>18 min</b>	
986 kW / 1500A		<b>8 min</b>	
1019 kW / 1550A		<b>5 min</b>	
1052 kW / 1600A		<b>3 min</b>	
1085 kW / 1650A		<b>2 min</b>	
1118 kW / 1700A		<b>1 min 26 sec</b>	
1150 kW / 1750A		<b>1 min 6 sec</b>	
1183 kW / 1800A		<b>52 sec</b>	
1216 kW / 1850A		<b>42sec</b>	

Mit einem Leistungsschalter

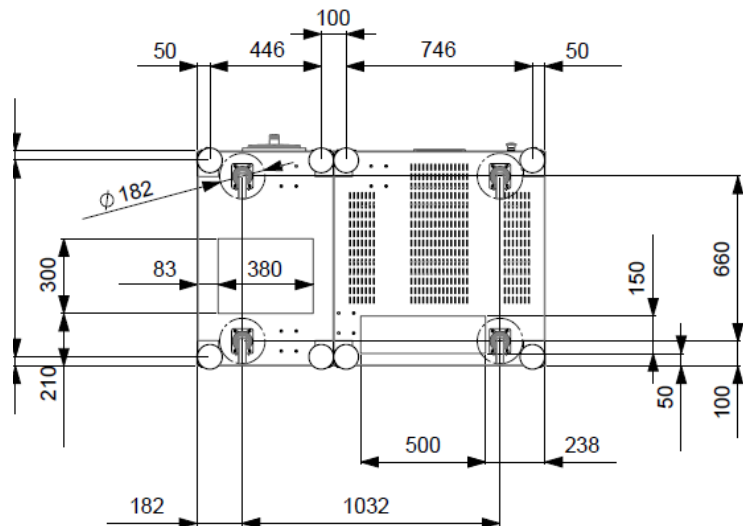
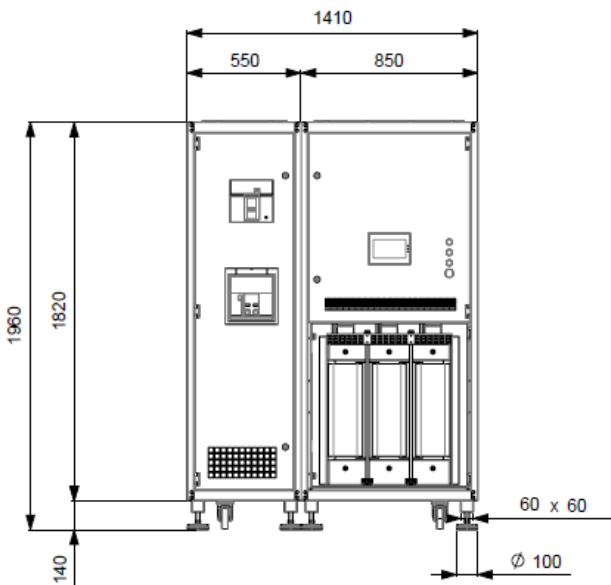
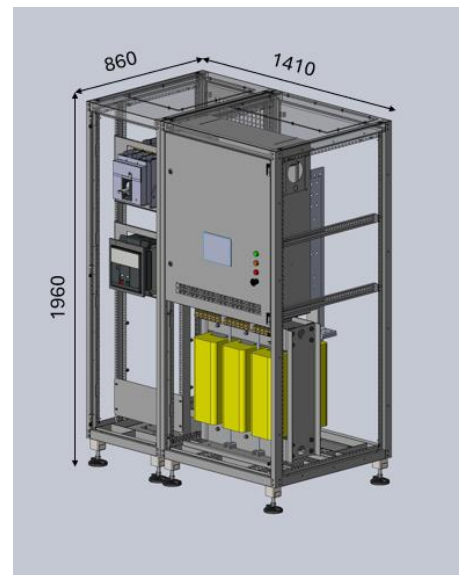

# Elektrischer Effizienzfilter *System 1250\_2*

Mit 2 Leistungsschaltern

Artikel-Nr	Filter	Leistungsschalter	Maße B/H/T	Gewicht	Icw Filter	Icu Schalter	Listenpreis o. MWSt.
EF125_L125_16_2	1250A	2 x LS 1600A	1950/1960/860 mm	1180 kg	50kA	50kA	87.058,-- €
EF125_L160_16_2	1250A	2 x LS 1600A	1950/1960/860 mm	1220 kg	50kA	50kA	96.446,-- €
EF125_L182_16_2	1250A	2 x LS 1600A	1950/1890/860 mm	1260 kg	50kA	50kA	101.869,-- €

## Leistungsebene 1250A-1850A

Filter Belastung		
822 kW / 1250A	Bleibt der Filter zugeschaltet (Wirkung)	geht nach dieser Zeit in den BYPASS
855 kW / 1300A		
887 kW / 1350A		
901 kW / 1370A	7 Std 19 min	
914 kW / 1390A	1 Std 50 min	
927 kW / 1410A	49 min	
940 kW / 1430A	27 min	
953 kW / 1450A	18 min	
986 kW / 1500A	8 min	
1019 kW / 1550A	5 min	
1052 kW / 1600A	3 min	
1085 kW / 1650A	2 min	
1118 kW / 1700A	1 min 26 sec	
1150 kW / 1750A	1 min 6 sec	
1183 kW / 1800A	52 sec	
1216 kW / 1850A	42sec	

Mit zwei Leistungsschaltern

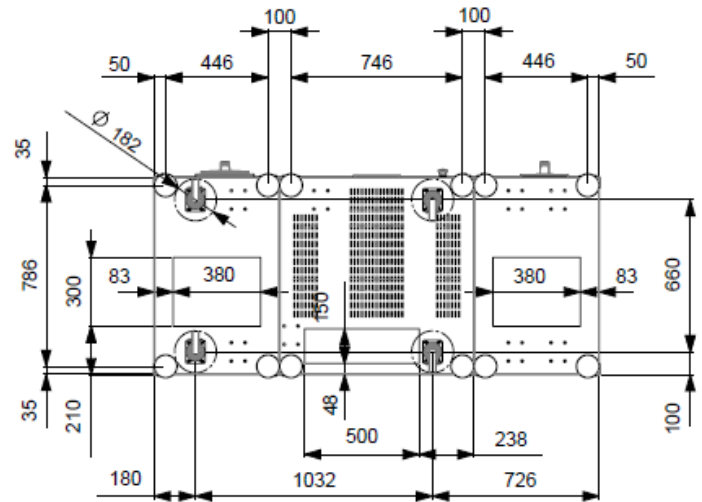
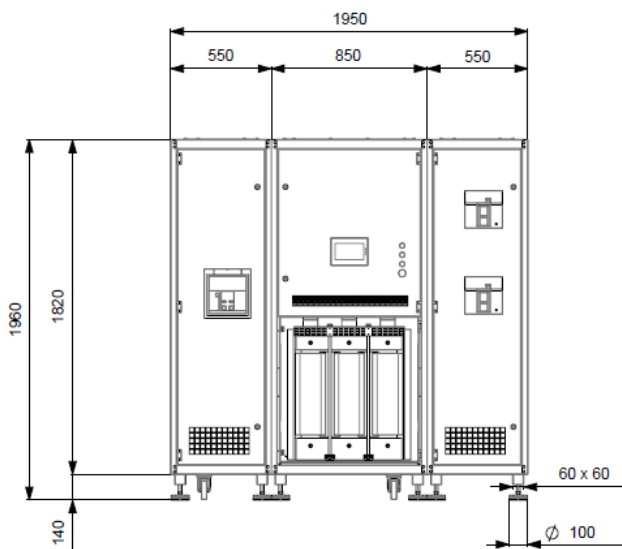
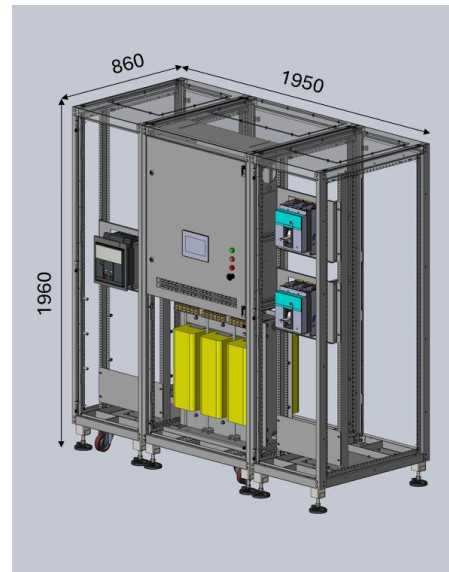

# Elektrischer Effizienzfilter System 1400\_1

Mit 1 Leistungsschalter

Artikel-Nr.	Filter	Leistungsschalter	Maße B/H/T	Gewicht	Icw Filter	Icu Schalter	Listenpreis o. MWSt.
EF140_L160_16_1	1400A	1 x LS 1600A	1410/1960/860 mm	1200 kg	50kA	50kA	85.915,-- €
EF140_L182_20_1	1400A	1 x LS 2000A	1410/1960/860 mm	1240 kg	50kA	42kA	93.256,-- €
EF140_L200_20_1	1400A	1 x LS 2000A	1410/1960/860 mm	1280 kg	50kA	42kA	97.890,-- €

## Leistungsebene 1400A-2000A

Filter Belastung		Bleibt der Filter zugeschaltet (Wirkung)	geht nach dieser Zeit in den BYPASS
920 kW / 1400A			
953 kW / 1450A			
986 kW / 1500A			
999 kW / 1520A		<b>9 Std 11 min</b>	
1012 kW / 1540A		<b>2 Std 17 min</b>	
1026 kW / 1560A		<b>1 Std 1 min</b>	
1039 kW / 1580A		<b>34 min</b>	
1052 kW / 1600A		<b>22 min</b>	
1085 kW / 1650A		<b>9 min</b>	
1118 kW / 1700A		<b>5 min</b>	
1150 kW / 1750A		<b>4 min</b>	
1183 kW / 1800A		<b>3 min</b>	
1216 kW / 1850A		<b>2 min</b>	
1249 kW / 1900A		<b>1 min 23 sec</b>	
1282 kW / 1950A		<b>1 min</b>	
1315 kW / 2000A		<b>53 sec</b>	

Mit einem Leistungsschalter

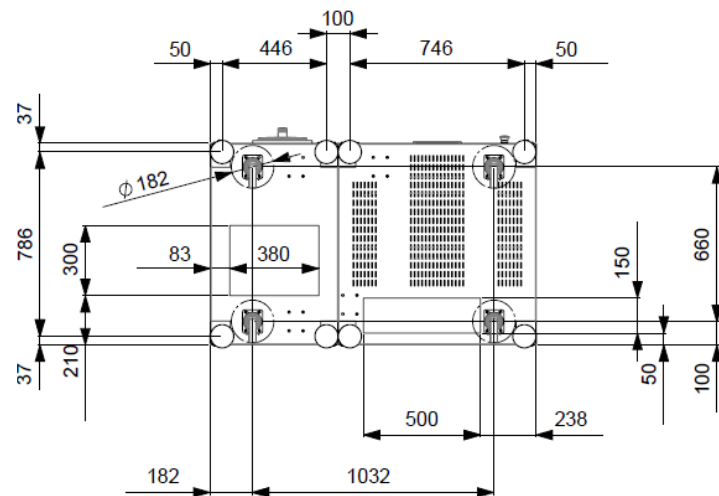
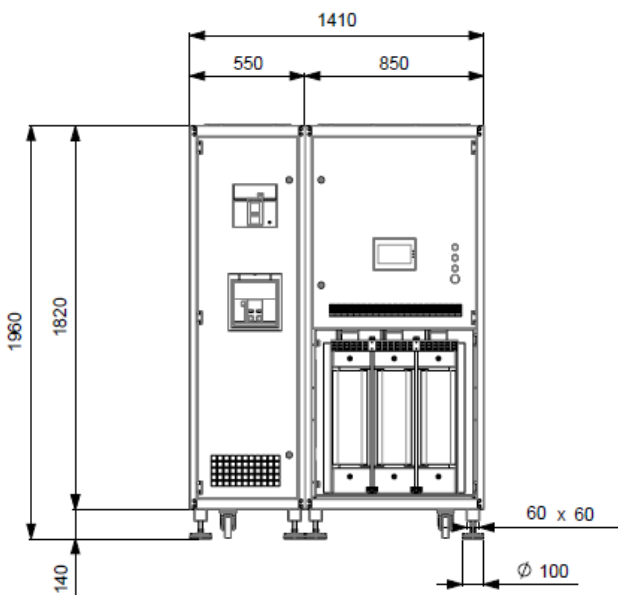
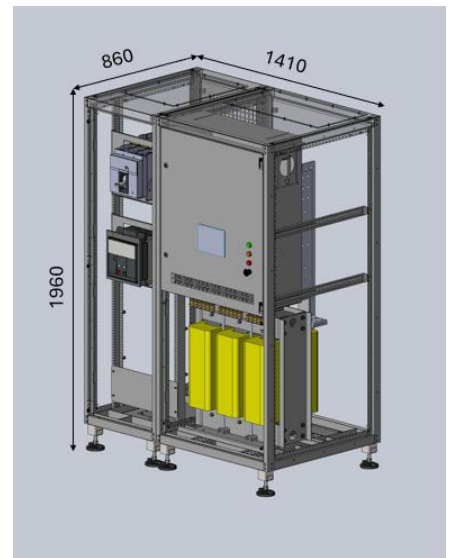

# Elektrischer Effizienzfilter *System 1400\_2*

Mit 2 Leistungsschaltern

Artikel-Nr.	Filter	Leistungsschalter	Maße B/H/T	Gewicht	Icw Filter	Icu Schalter	Listenpreis o. MWSt.
EF140_L160_16_2	1400A	2 x LS 1600A	1950/1960/860 mm	1300 kg	50kA	50kA	99.921,-- €
EF140_L182_16_2	1400A	2 x LS 1600A	1950/1960/860 mm	1340 kg	50kA	50kA	105.344,-- €
EF140_L200_16_2	1400A	2 x LS 1600A	1950/1960/860 mm	1380 kg	50kA	50kA	111.087,-- €

## Leistungsebene 1400A-2000A

Filter Belastung		Bleibt der Filter zugeschaltet (Wirkung)	geht nach dieser Zeit in den BYPASS
920 kW / 1400A			
953 kW / 1450A			
986 kW / 1500A			
999 kW / 1520A		<b>9 Std 11 min</b>	
1012 kW / 1540A		<b>2 Std 17 min</b>	
1026 kW / 1560A		<b>1 Std 1 min</b>	
1039 kW / 1580A		<b>34 min</b>	
1052 kW / 1600A		<b>22 min</b>	
1085 kW / 1650A		<b>9 min</b>	
1118 kW / 1700A		<b>5 min</b>	
1150 kW / 1750A		<b>4 min</b>	
1183 kW / 1800A		<b>3 min</b>	
1216 kW / 1850A		<b>2 min</b>	
1249 kW / 1900A		<b>1 min 23 sec</b>	
1282 kW / 1950A		<b>1 min</b>	
1315 kW / 2000A		<b>53 sec</b>	

Mit zwei Leistungsschaltern

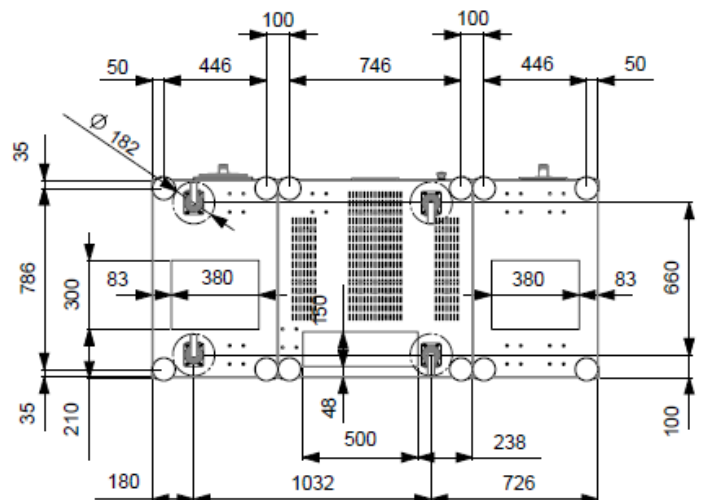
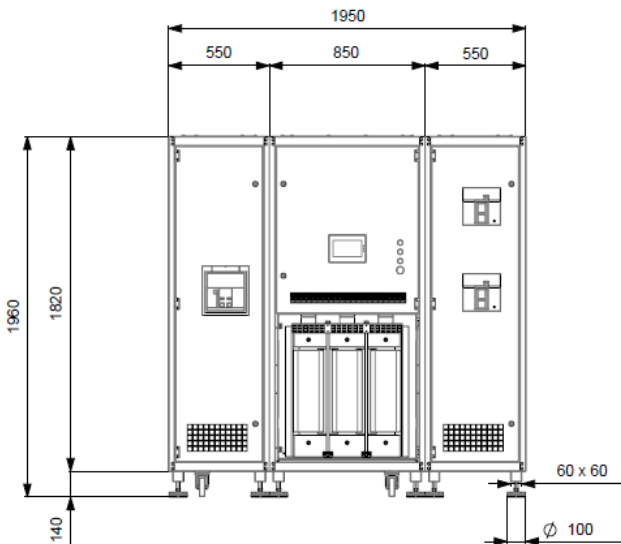
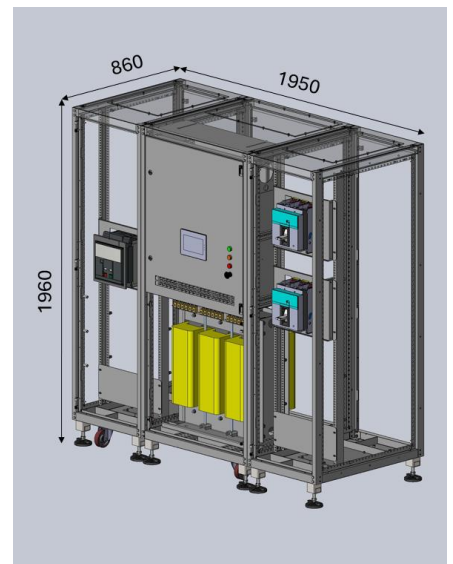

# Elektrischer Effizienzfilter *System 1600\_1*

Mit 1 Leistungsschalter

Artikel-Nr.	Filter	Leistungsschalter	Maße B/H/T	Gewicht	Icw Filter	Icu Schalter	Listenpreis o. MWSt.
EF160_L182_20_1	1600A	1 x LS 2000A	1500/1960/960 mm	1250 kg	65kA	66kA	104.931,-- €
EF160_L200_20_1	1600A	1 x LS 2000A	1500/1960/960 mm	1290 kg	65kA	66kA	112.153,-- €
EF160_L232_25_1	1600A	1 x LS 2500A	1500/1960/960 mm	1330 kg	65kA	66kA	119.304,-- €

## Leistungsebene 1600A-2300A

Filter Belastung	
1052 kW / 1600A	Bleibt der Filter zugeschaltet (Wirkung)
1085 kW / 1650A	
1118 kW / 1700A	
1131 kW / 1720A	12 Std
1144 kW / 1740A	3 Std
1157 kW / 1760A	1 Std 20 min
1170 kW / 1780A	45 min
1183 kW / 1800A	28 min
1216 kW / 1850A	13 min
1249 kW / 1900A	7 min
1282 kW / 1950A	5 min
1315 kW / 2000A	4 min
1348 kW / 2050A	3 min
1381 kW / 2100A	2 min
1413 kW / 2150A	1 min 25 sec
1446 kW / 2200A	1 min 9 sec
1479 kW / 2250A	1 min
1512 kW / 2300A	48 sec

geht nach dieser Zeit in den BYPASS

Mit einem Leistungsschalter

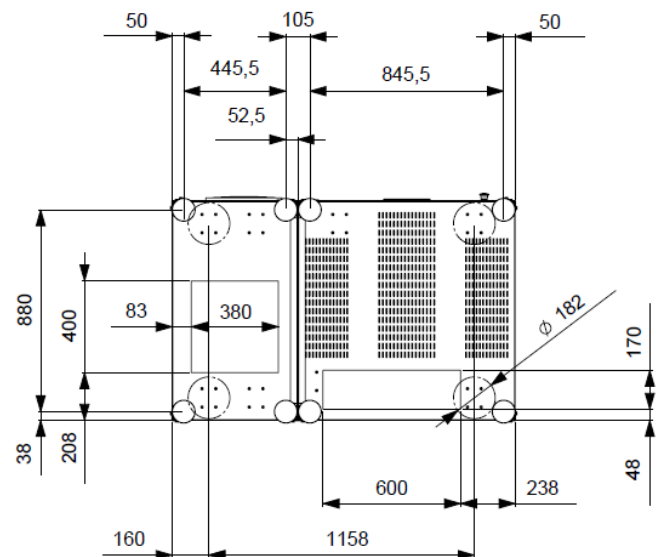
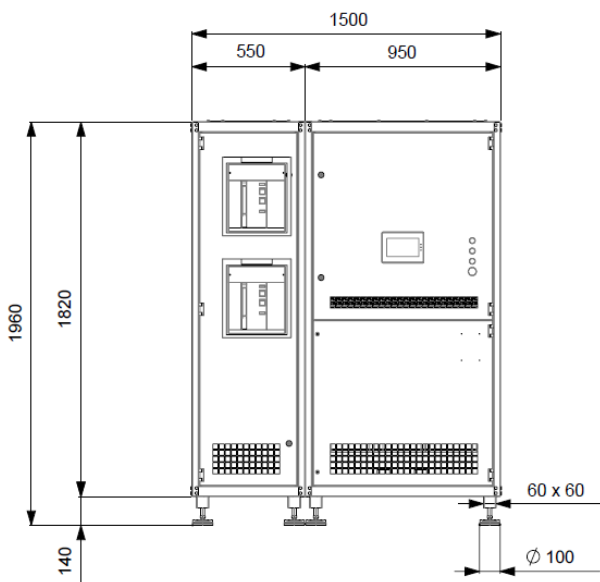
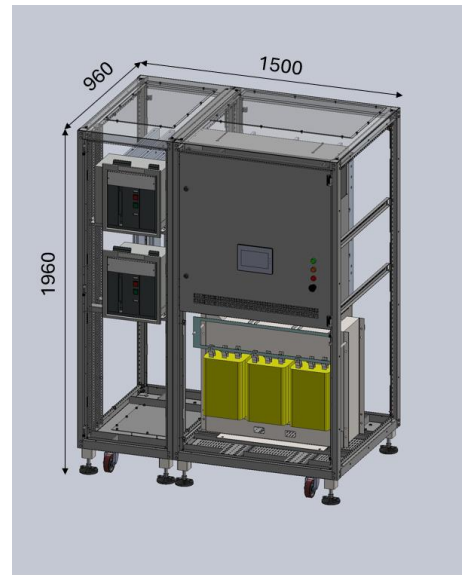

# Elektrischer Effizienzfilter *System 1600\_2*

Mit 2 Leistungsschaltern

Artikel-Nr.	Filter	Leistungsschalter	Maße B/H/T	Gewicht	Icw Filter	Icu Schalter	Listenpreis o. MWSt.
EF160_L182_16_2	1600A	2 x LS 1600A	2050/1960/960 mm	1480 kg	65kA	50kA	115.248,-- €
EF160_L200_16_2	1600A	2 x LS 1600A	2050/1960/960 mm	1520 kg	65kA	50kA	122.470,-- €
EF160_L232_16_2	1600A	2 x LS 1600A	2050/1960/960 mm	1550 kg	65kA	50kA	127.404,-- €

## Leistungsebene 1600A-2300A

Filter Belastung		Bleibt der Filter zugeschaltet (Wirkung)	geht nach dieser Zeit in den BYPASS
1052 kW / 1600A			
1085 kW / 1650A			
1118 kW / 1700A			
1131 kW / 1720A		<b>12 Std</b>	
1144 kW / 1740A		<b>3 Std</b>	
1157 kW / 1760A		<b>1 Std 20 min</b>	
1170 kW / 1780A		<b>45 min</b>	
1183 kW / 1800A		<b>28 min</b>	
1216 kW / 1850A		<b>13 min</b>	
1249 kW / 1900A		<b>7 min</b>	
1282 kW / 1950A		<b>5 min</b>	
1315 kW / 2000A		<b>4 min</b>	
1348 kW / 2050A		<b>3 min</b>	
1381 kW / 2100A		<b>2 min</b>	
1413 kW / 2150A		<b>1 min 25 sec</b>	
1446 kW / 2200A		<b>1 min 9 sec</b>	
1479 kW / 2250A		<b>1 min</b>	
1512 kW / 2300A		<b>48 sec</b>	

Mit zwei Leistungsschaltern

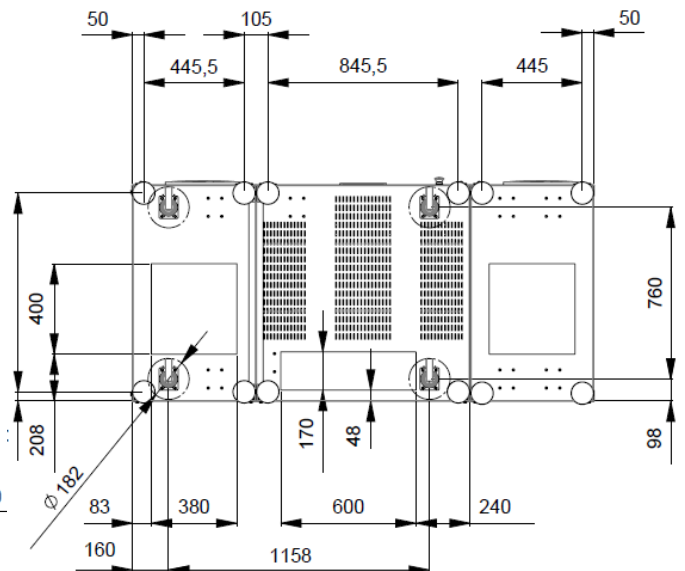
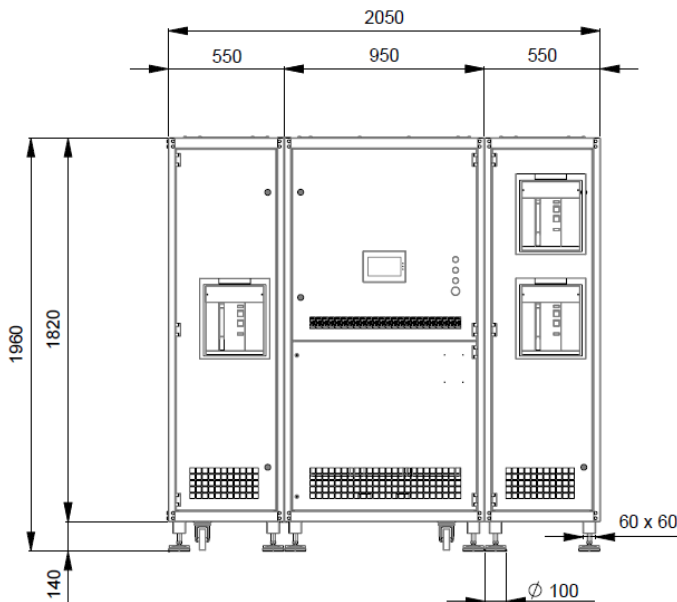
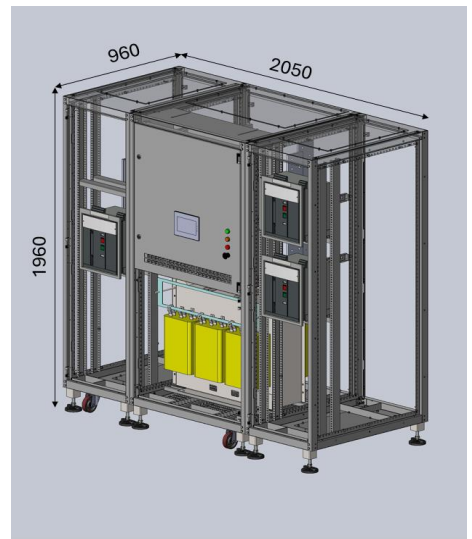

# Elektrischer Effizienzfilter *System 1800\_1*

Mit 1 Leistungsschalter

Artikel-Nr	Filter	Leistungsschalter	Maße B/H/T	Gewicht	Icw Filter	Icu Schalter	Listenpreis o. MWSt.
EF180_L200_20_1	1800A	1 x LS 2000A	1500/1960/960 mm	1350 kg	65kA	66kA	115.863,-- €
EF180_L250_25_1	1800A	1 x LS 2500A	1500/1960/960 mm	1400 kg	65kA	66kA	129.467,-- €

## Leistungsebene 1800A-2650A

Filter Belastung		Bleibt der Filter zugeschaltet (Wirkung)	geht nach dieser Zeit in den BYPASS
1183 kW / 1800A			
1216 kW / 1850A			
1249 kW / 1900A			
1262 kW / 1920A		<b>15 Std 11 min</b>	
1275 kW / 1940A		<b>3 Std 48 min</b>	
1289 kW / 1960A		<b>1 Std 41 min</b>	
1302 kW / 1980A		<b>57 min</b>	
1315 kW / 2000A		<b>35 min</b>	
1348 kW / 2050A		<b>16 min</b>	
1381 kW / 2100A		<b>9 min</b>	
1413 kW / 2150A		<b>6 min</b>	
1446 kW / 2200A		<b>5 min</b>	
1479 kW / 2250A		<b>4 min</b>	
1512 kW / 2300A		<b>3 min</b>	
1545 kW / 2350A		<b>2 min</b>	
1578 kW / 2400A		<b>1 min 27 sec</b>	
1611 kW / 2450A		<b>1 min 12 sec</b>	
1644 kW / 2500A		<b>1 min</b>	

Mit einem Leistungsschalter

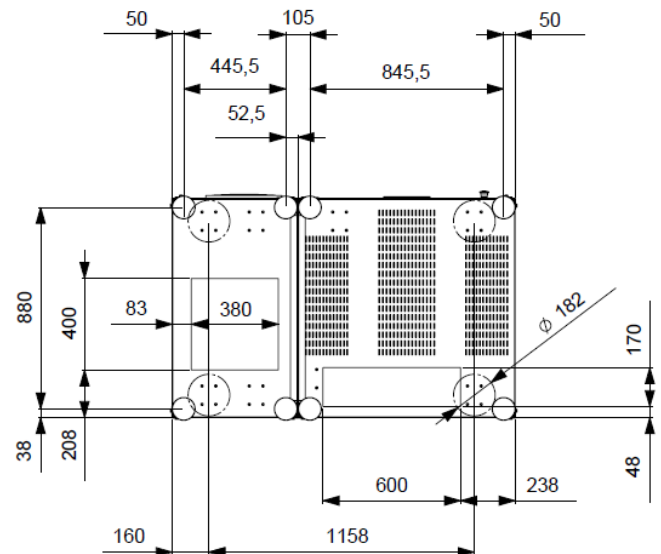
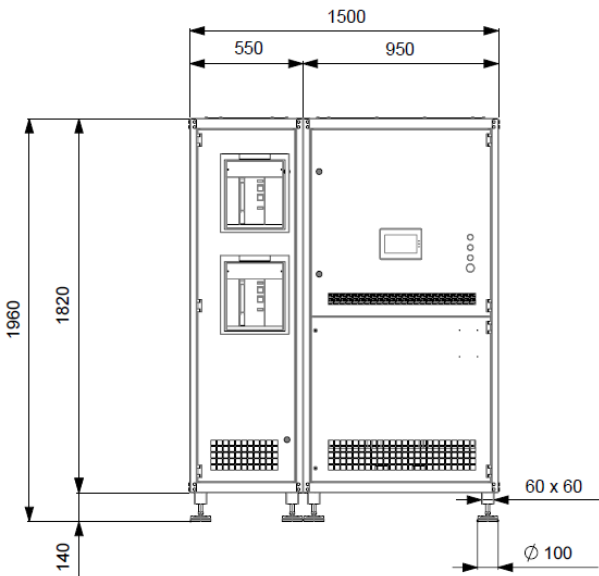
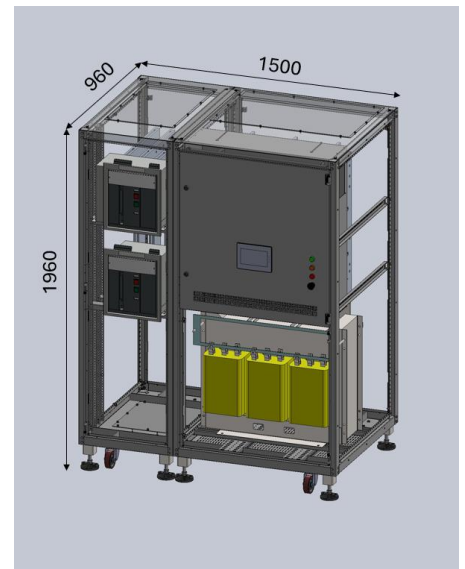

# Elektrischer Effizienzfilter *System 1800\_2*

Mit 2 Leistungsschaltern

Artikel-Nr	Filter	Leistungsschalter	Maße B/H/T	Gewicht	Icw Filter	Icu Schalter	Listenpreis o. MWSt.
EF180_L200_16_2	1800A	2 x LS 1600A	2050/1960/960 mm	1480 kg	65kA	50kA	126.181,-- €
EF180_L250_16_2	1800A	2 x LS 1600A	2050/1960/960 mm	1530kg	65kA	50kA	138.473,-- €

## Leistungsebene 1800A-2650A

Filter Belastung		Bleibt der Filter zugeschaltet (Wirkung)	geht nach dieser Zeit in den BYPASS
1183 kW / 1800A			
1216 kW / 1850A			
1249 kW / 1900A			
1262 kW / 1920A		<b>15 Std 11 min</b>	
1275 kW / 1940A		<b>3 Std 48 min</b>	
1289 kW / 1960A		<b>1 Std 41 min</b>	
1302 kW / 1980A		<b>57 min</b>	
1315 kW / 2000A		<b>35 min</b>	
1348 kW / 2050A		<b>16 min</b>	
1381 kW / 2100A		<b>9 min</b>	
1413 kW / 2150A		<b>6 min</b>	
1446 kW / 2200A		<b>5 min</b>	
1479 kW / 2250A		<b>4 min</b>	
1512 kW / 2300A		<b>3 min</b>	
1545 kW / 2350A		<b>2 min</b>	
1578 kW / 2400A		<b>1 min 27 sec</b>	
1611 kW / 2450A		<b>1 min 12 sec</b>	
1644 kW / 2500A		<b>1 min</b>	

Mit zwei Leistungsschaltern

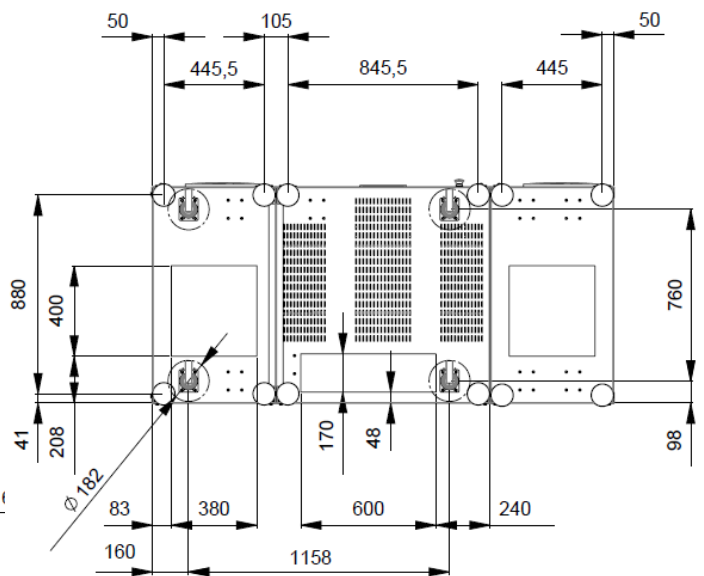
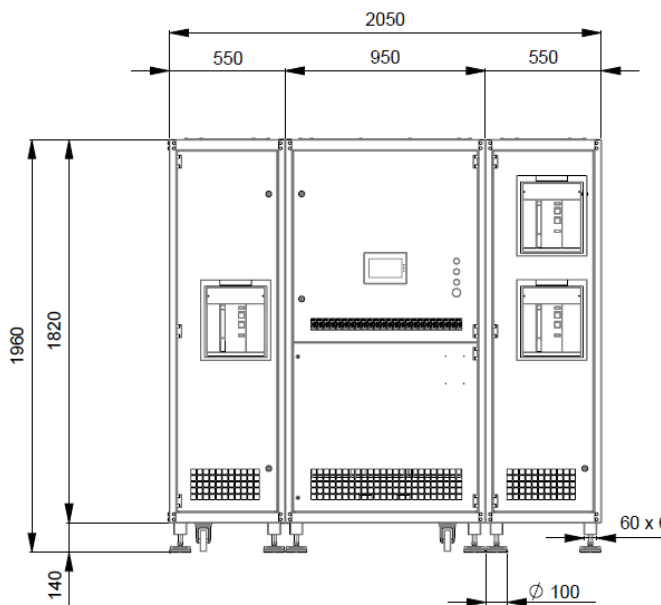
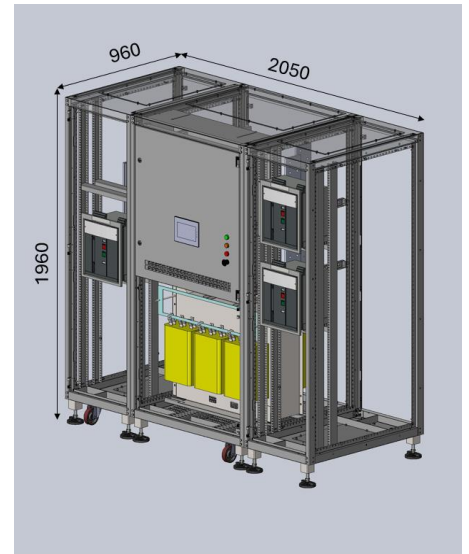



# Elektrischer Effizienzfilter *System 2000\_1*

## Mit 1 Leistungsschalter

Artikel-Nr	Filter	Leistungsschalter	Maße B/H/T	Gewicht	Icw Filter	Icu Schalter	Listenpreis o. MWSt.
EF200_L200_20_1	2000A	1 x LS 2000A	1500/1960/960 mm	1650 kg	65kA	66kA	127.266,-- €
EF200_L250_25_1	2000A	1 x LS 2500A	1500/1960/960 mm	1700 kg	65kA	66kA	141.866,-- €
EF200_L320_32_1	2000A	1 x LS 3200A	1500/1960/960 mm	1780 kg	65kA	66kA	162.661,-- €

## Leistungsebene 2000A-2850A

Filter Belastung		Bleibt der Filter zugeschaltet (Wirkung)	geht nach dieser Zeit in den BYPASS
1315 kW / 2000A			
1348 kW / 2050A			
1381 kW / 2100A			
1394 kW / 2120A		<b>18 Std 45 min</b>	
1417 kW / 2140A		<b>4 Std 41 min</b>	
1420 kW / 2160A		<b>2 Std 5 min</b>	
1433 kW / 2180A		<b>1 Std 10 min</b>	
1446 kW / 2200A		<b>45 min</b>	
1479 kW / 2250A		<b>20 min</b>	
1512 kW / 2300A		<b>11 min</b>	
1545 kW / 2350A		<b>7 min</b>	
1578 kW / 2400A		<b>5 min</b>	
1611 kW / 2450A		<b>4 min</b>	
1644 kW / 2500A		<b>3 min</b>	
1676 kW / 2550A		<b>2 min</b>	
1709 kW / 2600A		<b>1 min 48 sec</b>	
1742 kW / 2650A		<b>1 min 29 sec</b>	
1775 kW / 2700A		<b>1 min 15 sec</b>	
1808 kW / 2750A		<b>1 min</b>	
1841 kW / 2800A		<b>55 sec</b>	
1874 kW / 2850A		<b>48 sec</b>	

## Mit einem Leistungsschalter

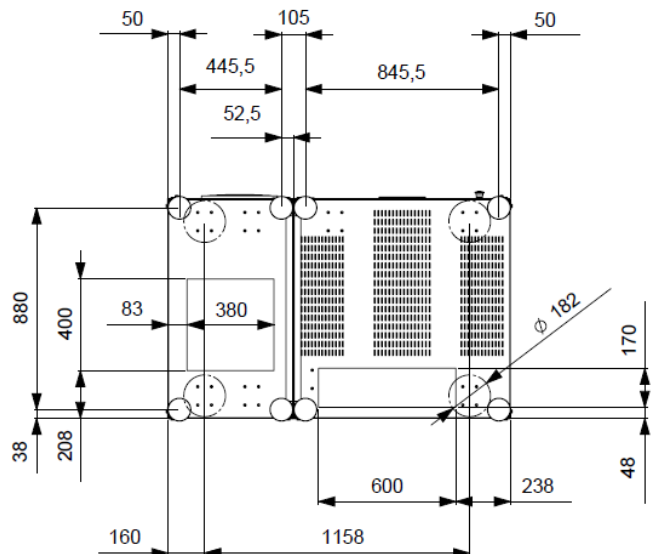
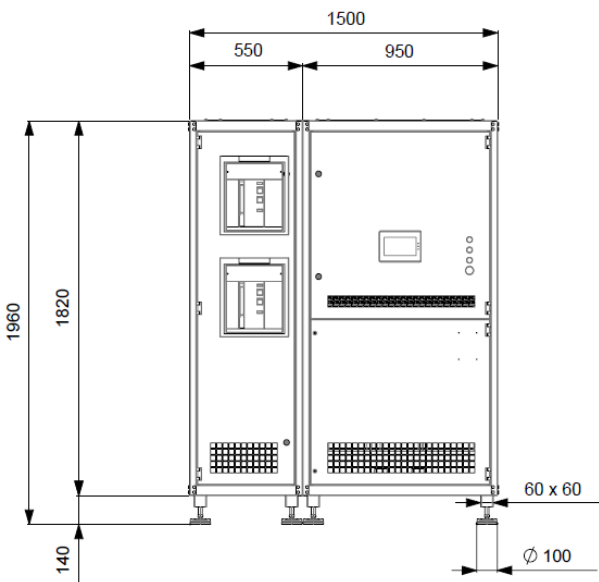
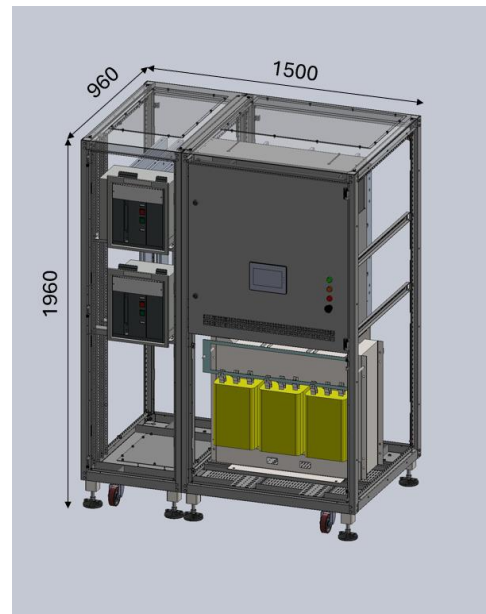

# Elektrischer Effizienzfilter System 2000\_2

Mit 2 Leistungsschaltern

Artikel-Nr	Filter	Leistungsschalter	Maße B/H/T	Gewicht	Icw Filter	Icu Schalter	Listenpreis o. MWSt.
EF200_L200_16_2	2000A	2 x LS 1600A	2050/1960/960 mm	1790 kg	65kA	50kA	138.485,-- €
EF200_L250_16_2	2000A	2 x LS 1600A	2050/1960/960 mm	1840 kg	65kA	50kA	153.032,-- €
EF200_L320_16_2	2000A	2 x LS 1600A	2050/1960/960 mm	1920 kg	65kA	50kA	169.825,-- €
EF200_L200_20_2	2000A	2 x LS 2000A	2050/1960/960 mm	1820 kg	65kA	42kA	145.001,-- €
EF200_L250_20_2	2000A	2 x LS 2000A	2050/1960/960 mm	1870 kg	65kA	42kA	159.548,-- €
EF200_L320_20_2	2000A	2 x LS 2000A	2050/1960/960 mm	1950 kg	65kA	42kA	176.341,-- €
EF200_L200_25_2	2000A	2 x LS 2500A	2050/1960/960 mm	1850 kg	65kA	66kA	153.047,-- €
EF200_L250_25_2	2000A	2 x LS 2500A	2050/1960/960 mm	1900 kg	65kA	66kA	168.097,-- €
EF200_L320_25_2	2000A	2 x LS 2500A	2050/1960/960 mm	1980 kg	65kA	66kA	190.307,-- €

## Leistungsebene 2000A-2850A

Filter Belastung		Bleibt der Filter zugeschaltet (Wirkung)	geht nach dieser Zeit in den BYPASS
1315 kW / 2000A			
1348 kW / 2050A			
1381 kW / 2100A			
1394 kW / 2120A		<b>18 Std 45 min</b>	
1417 kW / 2140A		<b>4 Std 41 min</b>	
1420 kW / 2160A		<b>2 Std 5 min</b>	
1433 kW / 2180A		<b>1 Std 10 min</b>	
1446 kW / 2200A		<b>45 min</b>	
1479 kW / 2250A		<b>20 min</b>	
1512 kW / 2300A		<b>11 min</b>	
1545 kW / 2350A		<b>7 min</b>	
1578 kW / 2400A		<b>5 min</b>	
1611 kW / 2450A		<b>4 min</b>	
1644 kW / 2500A		<b>3 min</b>	
1676 kW / 2550A		<b>2 min</b>	
1709 kW / 2600A		<b>1 min 48 sec</b>	
1742 kW / 2650A		<b>1 min 29 sec</b>	
1775 kW / 2700A		<b>1 min 15 sec</b>	
1808 kW / 2750A		<b>1 min</b>	
1841 kW / 2800A		<b>55 sec</b>	
1874 kW / 2850A		<b>48 sec</b>	

Mit zwei Leistungsschaltern

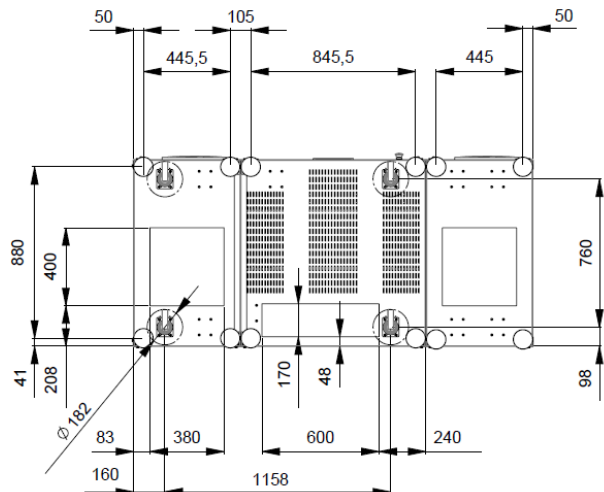
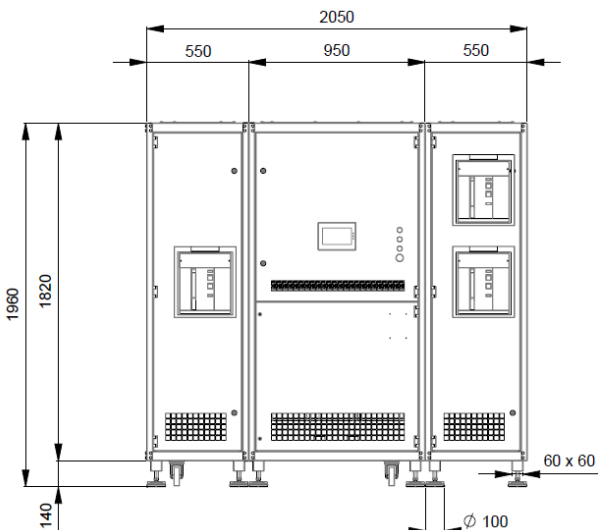
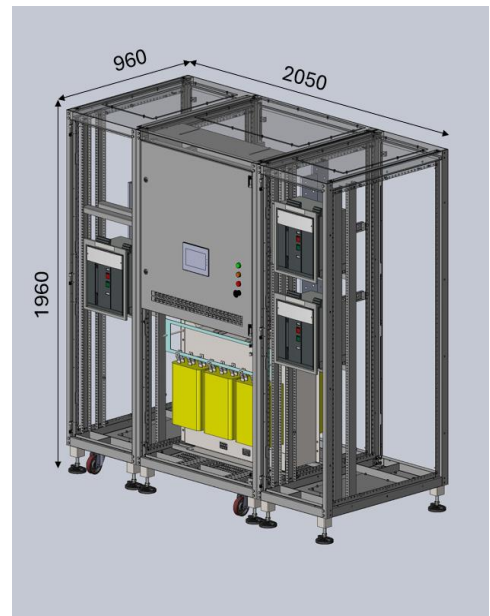

# Elektrischer Effizienzfilter *System 2500\_1*

Mit 1 Leistungsschalter

Artikel-Nr	Filter	Leistungsschalter	Maße B/H/T	Gewicht	Icw Filter	Icu Schalter	Listenpreis o. MWSt.
EF250_L250_25_1	2500A	1 x LS 2500A	1750/2237,5/1120 mm	1850 kg	65kA	66kA	153.200,-- €
EF250_L320_32_1	2500A	1 x LS 3200A	1750/2237,5/1120 mm	1910 kg	65kA	66kA	172.096,-- €
EF250_L362_40_1	2500A	1 x LS 4000A	1750/2237,5/1120 mm	1970 kg	65kA	66kA	187.871,-- €

## Leistungsebene 2500A-3400A

Filter Belastung		Bleibt der Filter zugeschaltet (Wirkung)	geht nach dieser Zeit in den BYPASS
1644 kW / 2500A			
1676 kW / 2550A			
1709 kW / 2600A			
1739 kW / 2645A		29 Std 17 min	
1752 kW / 2665A		7 Std 19 min	
1765 kW / 2685A		3 Std 15 min	
1778 kW / 2705A		1 Std 49 min	
1808 kW / 2750A		45 min	
1841 kW / 2800A		23 min	
1874 kW / 2850A		13 min	
1906 kW / 2900A		9 min	
1939 kW / 2950A		7 min	
1972 kW / 3000A		5 min	
2005 kW / 3050A		4 min	
2038 kW / 3100A		3 min	
2071 kW / 3150A		2 min 33 sec	
2104 kW / 3200A		2 min 8 sec	
2137 kW / 3250A		1 min 48 sec	
2169 kW / 3300A		1 min 33 sec	
2202 kW / 3350A		1 min 20 sec	
2235 kW / 3400A		1 min 10 sec	

Mit einem Leistungsschalter

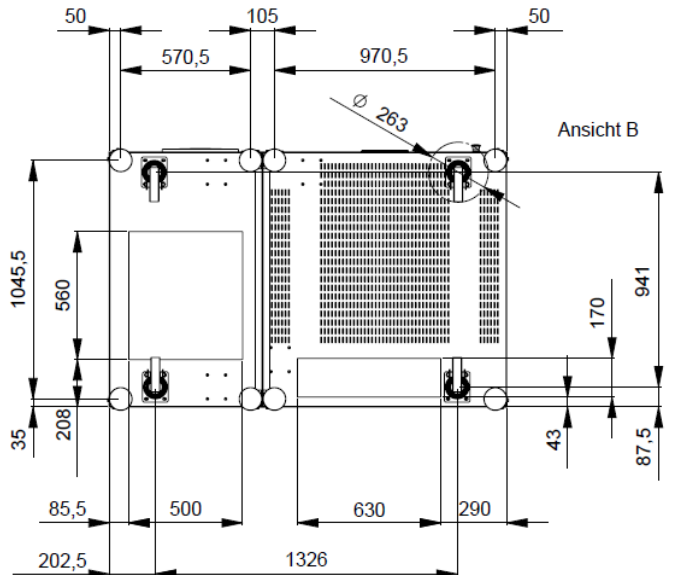
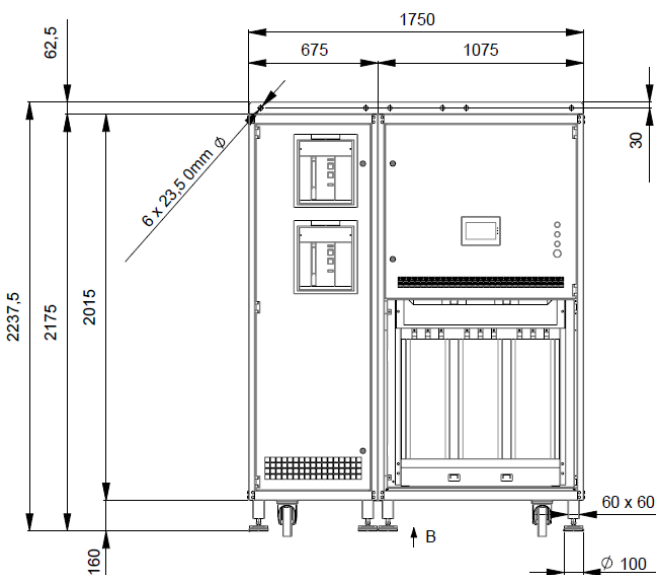
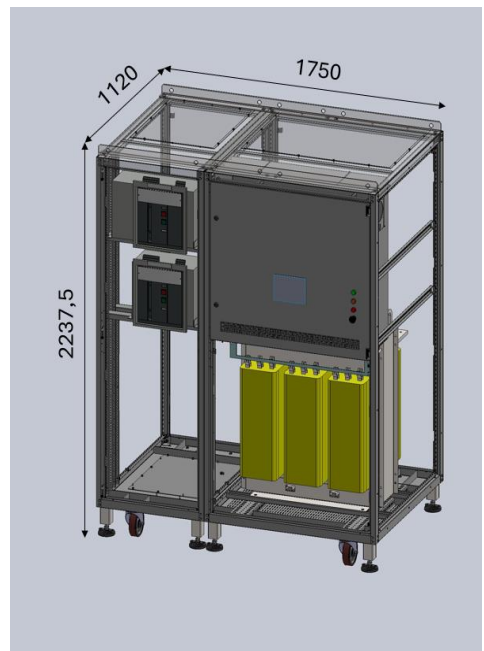

# Elektrischer Effizienzfilter *System 2500\_2*

## Mit 2-3 Leistungsschaltern

Artikel-Nr	Filter	Leistungsschalter	Maße B/H/T	Gewicht	Icw Filter	Icu Schalter	Listenpreis o. MWSt.
EF250_L250_16_2	2500A	2 x LS 1600A	2425/2237,5/1120 mm	2070 kg	65kA	50kA	164.513,-- €
EF250_L320_16_2	2500A	2 x LS 1600A	2425/2237,5/1120 mm	2110 kg	65kA	50kA	182.977,-- €
EF250_L250_20_2	2500A	2 x LS 2000A	2425/2237,5/1120 mm	2180 kg	65kA	42kA	170.996,-- €
EF250_L320_20_2	2500A	2 x LS 2000A	2425/2237,5/1120 mm	2190 kg	65kA	42kA	189.457,-- €
EF250_L362_20_2	2500A	2 x LS 2000A	2425/2237,5/1120 mm	2200 kg	65kA	42kA	204.697,-- €
EF250_L250_25_2	2500A	2 x LS 2500A	2425/2237,5/1120 mm	2230 kg	65kA	66kA	177.391,-- €
EF250_L320_25_2	2500A	2 x LS 2500A	2425/2237,5/1120 mm	2240 kg	65kA	66kA	195.578,-- €
EF250_L362_25_2	2500A	2 x LS 2500A	2425/2237,5/1120 mm	2280 kg	65kA	66kA	215.807,-- €
EF250_L250_16_3	2500A	3 x LS 1600A	2425/2237,5/1120 mm	2200 kg	65kA	50kA	178.231,-- €

## Leistungsebene 2500A-3400A

Filter Belastung		Bleibt der Filter zugeschaltet (Wirkung)	geht nach dieser Zeit in den BYPASS
1644 kW / 2500A			
1676 kW / 2550A			
1709 kW / 2600A			
1739 kW / 2645A		<b>29 Std 17 min</b>	
1752 kW / 2665A		<b>7 Std 19 min</b>	
1765 kW / 2685A		<b>3 Std 15 min</b>	
1778 kW / 2705A		<b>1 Std 49 min</b>	
1808 kW / 2750A		<b>45 min</b>	
1841 kW / 2800A		<b>23 min</b>	
1874 kW / 2850A		<b>13 min</b>	
1906 kW / 2900A		<b>9 min</b>	
1939 kW / 2950A		<b>7min</b>	
1972 kW / 3000A		<b>5 min</b>	
2005 kW / 3050A		<b>4 min</b>	
2038 kW / 3100A		<b>3 min</b>	
2071 kW / 3150A		<b>2 min 33 sec</b>	
2104 kW / 3200A		<b>2 min 8 sec</b>	
2137 kW / 3250A		<b>1 min 48 sec</b>	
2169 kW / 3300A		<b>1 min 33 sec</b>	
2202 kW / 3350A		<b>1 min 20 sec</b>	
2235 kW / 3400A		<b>1 min 10 sec</b>	

## Mit zwei Leistungsschaltern

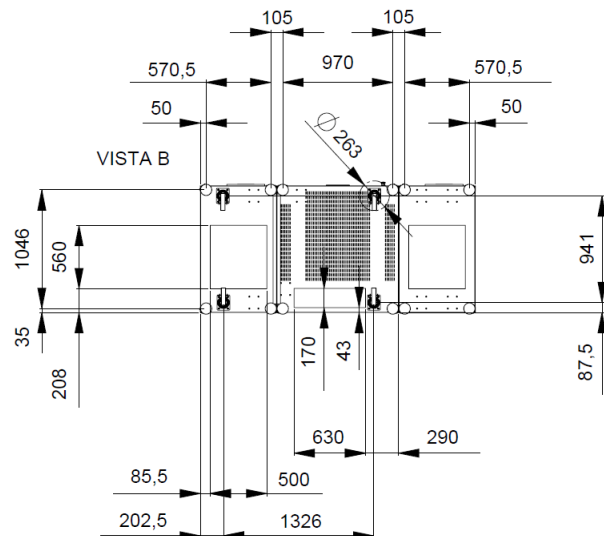
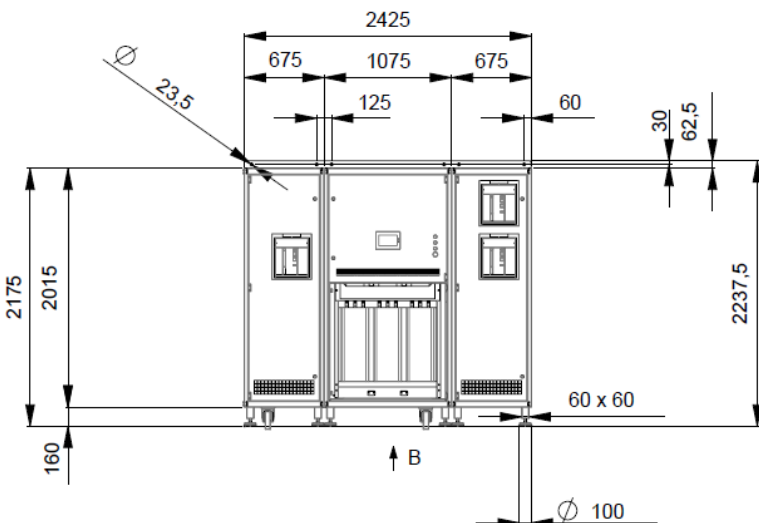
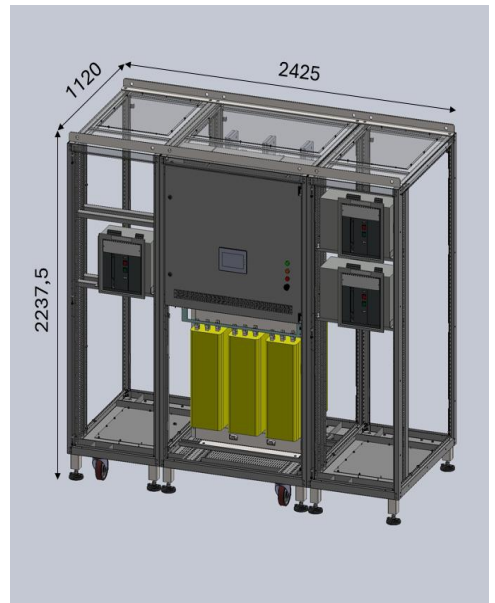

# Elektrischer Effizienzfilter System 3200\_1

Mit 1 Leistungsschalter

Artikel-Nr	Filter	Leistungsschalter	Maße B/H/T	Gewicht	Icw Filter	Icu Schalter	Listenpreis o. MWSt.
EF320_L320_32_1	3200A	1 x LS 3200A	1750/2237,5/1120 mm	2050 kg	65kA	66kA	200.825,-- €
EF320_L320_40_1	3200A	1 x LS 4000A	1750/2237,5/1120 mm	2100 kg	65kA	66kA	204.807,-- €
EF320_L400_40_1	3200A	1 x LS 4000A	1750/2237,5/1120 mm	2150 kg	65kA	66kA	229.640,-- €

## Leistungsebene 3200A-4050A

Filter Belastung		Bleibt der Filter zugeschaltet (Wirkung)	geht nach dieser Zeit in den BYPASS
2104 kW / 3200A			
2137 kW / 3250A			
2169 kW / 3300A			
2183 kW / 3320A		<b>48 Std</b>	
2196 kW / 3340A		<b>12 Std</b>	
2209 kW / 3360A		<b>5 Std 20 min</b>	
2222 kW / 3380A		<b>3 Std</b>	
2235 kW / 3400A		<b>1 Std 55 min</b>	
2268 kW / 3450A		<b>51 min</b>	
2301 kW / 3500A		<b>29 min</b>	
2334 kW / 3550A		<b>18min</b>	
2367 kW / 3600A		<b>13 min</b>	
2400 kW / 3650A		<b>9 min</b>	
2432 kW / 3700A		<b>7 min</b>	
2465 kW / 3750A		<b>6 min</b>	
2498 kW / 3800A		<b>5 min</b>	
2531 kW / 3850A		<b>4 min</b>	
2564 kW / 3900A		<b>3 min</b>	
2597 kW / 3950A		<b>2 min 44 sec</b>	
2630 kW / 4000A		<b>2 min 21 sec</b>	
2662 kW / 4050A		<b>2 min</b>	

Mit einem Leistungsschalter

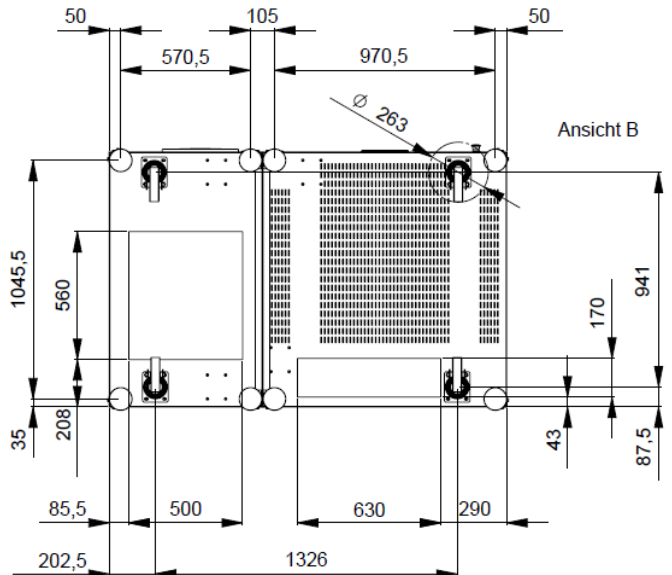
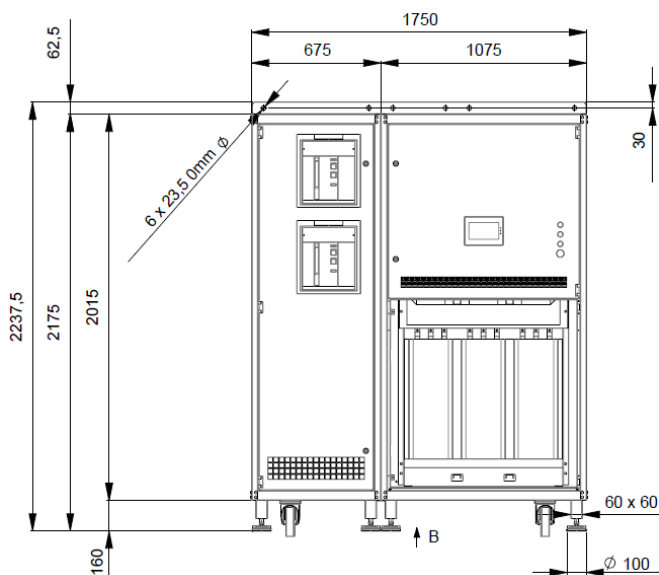
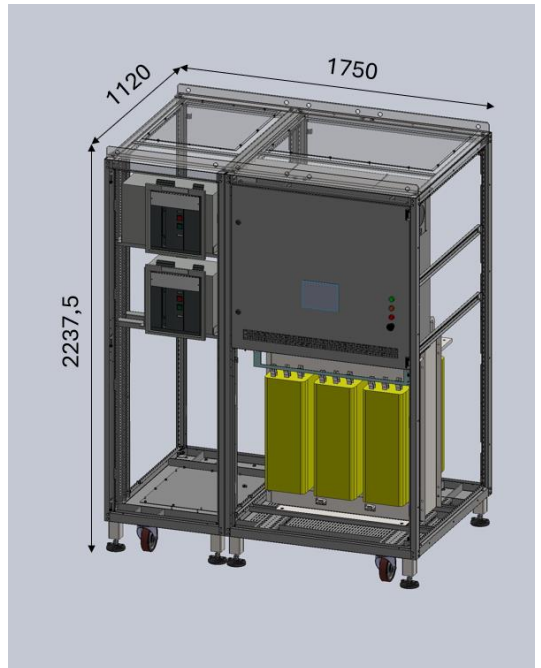

# Elektrischer Effizienzfilter *System 3200\_2*

Mit 2 Leistungsschaltern

Artikel-Nr	Filter	Leistungsschalter	Maße B/H/T	Gewicht	Icw Filter	Icu Schalter	Listenpreis o. MWSt.
EF320_L320_16_2	3200A	2 x LS 1600A	2425/2237,5/1120 mm	2190 kg	65kA	50kA	211.805,-- €
EF320_L320_20_2	3200A	2 x LS 2000A	2425/2237,5/1120 mm	2230 kg	65kA	42kA	221.515,-- €
EF320_L400_20_2	3200A	2 x LS 2000A	2425/2237,5/1120 mm	2270 kg	65kA	42kA	245.317,-- €
EF320_L320_25_2	3200A	2 x LS 2500A	2425/2237,5/1120 mm	2320 kg	65kA	66kA	227.782,-- €
EF320_L400_25_2	3200A	2 x LS 2500A	2425/2237,5/1120 mm	2350 kg	65kA	66kA	252.403,-- €
EF320_L320_32_2	3200A	2 x LS 3200A	2425/2237,5/1120 mm	2360 kg	65kA	66kA	231.514,-- €
EF320_L400_32_2	3200A	2 x LS 3200A	2425/2237,5/1120 mm	2390 kg	65kA	66kA	255.824,-- €

## Leistungsebene 3200A-4050A

Filter Belastung		Bleibt der Filter zugeschaltet (Wirkung)
2104 kW / 3200A		
2137 kW / 3250A		
2169 kW / 3300A		
2183 kW / 3320A	<b>48 Std</b>	
2196 kW / 3340A	<b>12 Std</b>	
2209 kW / 3360A	<b>5 Std 20 min</b>	
2222 kW / 3380A	<b>3 Std</b>	
2235 kW / 3400A	<b>1 Std 55 min</b>	
2268 kW / 3450A	<b>51 min</b>	
2301 kW / 3500A	<b>29 min</b>	
2334 kW / 3550A	<b>18min</b>	
2367 kW / 3600A	<b>13 min</b>	
2400 kW / 3650A	<b>9 min</b>	
2432 kW / 3700A	<b>7 min</b>	
2465 kW / 3750A	<b>6 min</b>	
2498 kW / 3800A	<b>5 min</b>	
2531 kW / 3850A	<b>4 min</b>	
2564 kW / 3900A	<b>3 min</b>	
2597 kW / 3950A	<b>2 min 44 sec</b>	
2630 kW / 4000A	<b>2 min 21 sec</b>	
2662 kW / 4050A	<b>2 min</b>	

Mit zwei Leistungsschaltern

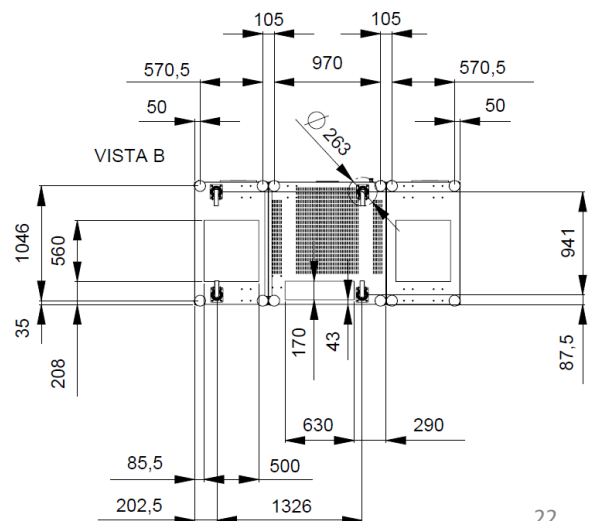
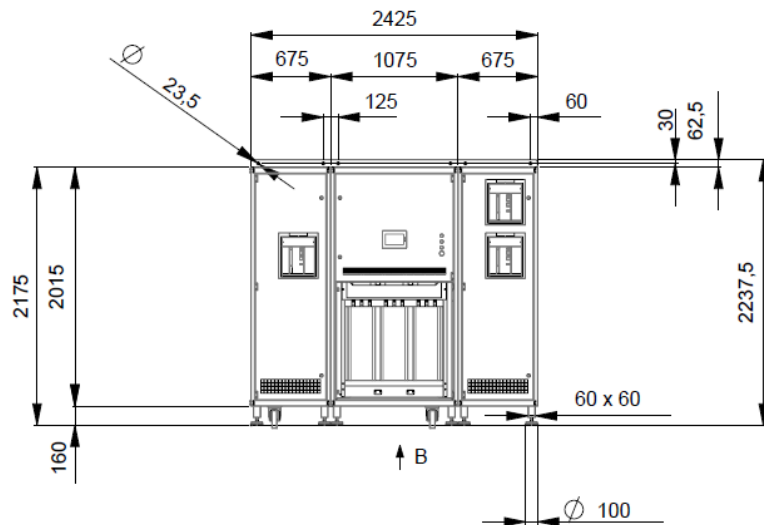
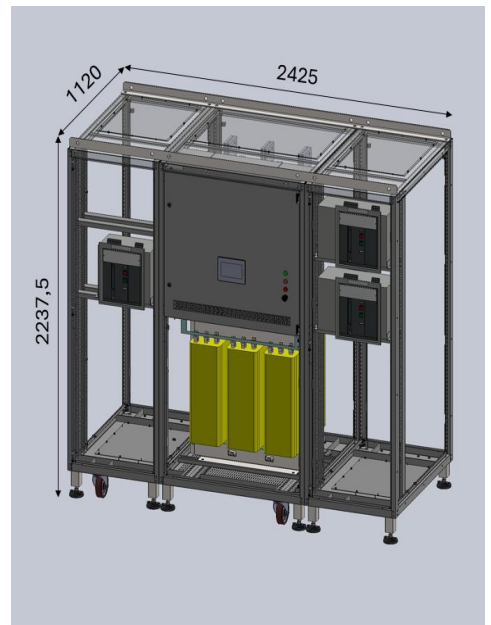

# Elektrischer Effizienzfilter *System 4000\_1*

Mit 1 Leistungsschalter

Artikel-Nr	Filter	Leistungsschalter	Maße B/H/T	Gewicht	Icw Filter	Icu Schalter	Listenpreis o. MWSt.
EF400_L400_40_1	4000A	1 x LS 4000A	1900/2410/1200 mm	2550 kg	65kA	66kA	239.360,-- €

## Leistungsebene 4000A-4850A

Filter Belastung		Bleibt der Filter zugeschaltet (Wirkung)	geht nach dieser Zeit in den BYPASS	
2630 kW / 4000A				
2662 kW / 4050A				
2682 kW / 4080A				
2692 kW / 4095A	75 Std			
2705 kW / 4115A	18 Std 45min			
2718 kW / 4135A	8 Std 20min			
2731 kW / 4155A	4 Std 41min 18sec			
2761 kW / 4200A	1 Std 55min 12sec			
2794 kW / 4250A	58min 48sec			
2827 kW / 4300A	35min 36sec			

Mit einem Leistungsschalter

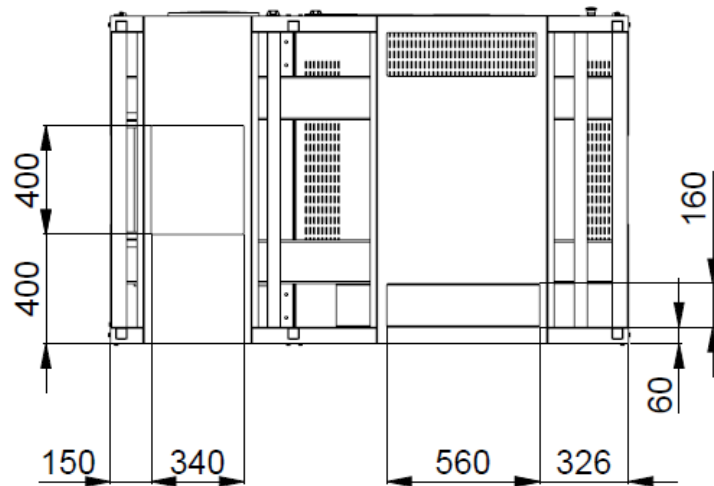
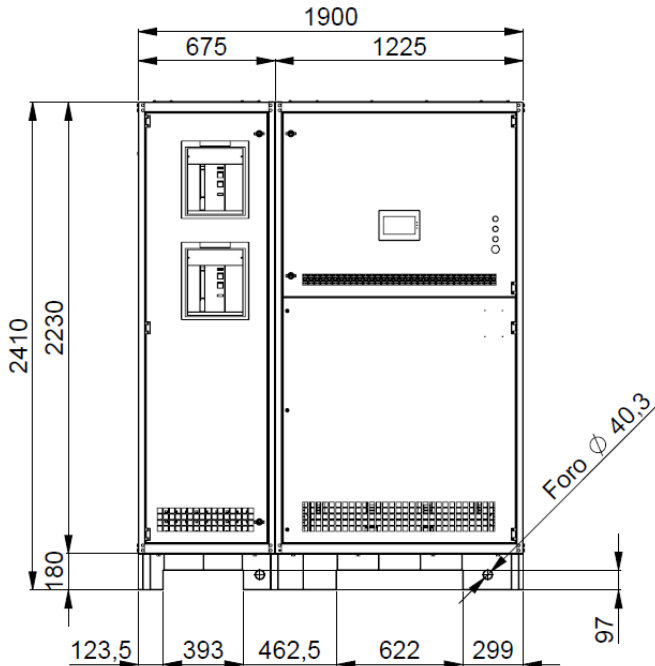
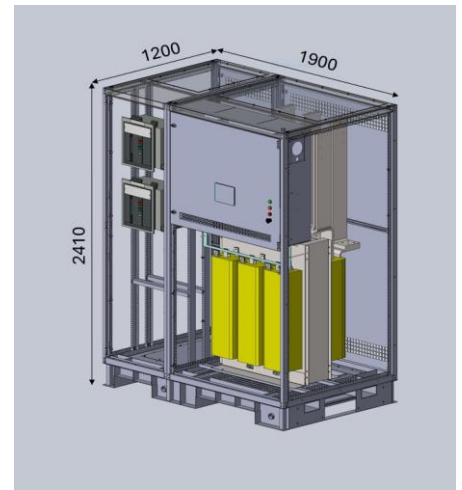

# Elektrischer Effizienzfilter *System 4000\_2*

Mit 2 Leistungsschaltern

Artikel-Nr	Filter	Leistungsschalter	Maße B/H/T	Gewicht	Icw Filter	Icu Schalter	Listenpreis o. MWSt.
EF400_L400_20_2	4000A	2 x LS 2000A	2575/2490/1200 mm	2700 kg	65kA	42kA	256.485,-- €
EF400_L400_25_2	4000A	2 x LS 2500A	2575/2490/1200 mm	2750 kg	65kA	66kA	262.041,-- €
EF400_L400_32_2	4000A	2 x LS 3200A	2575/2490/1200 mm	2800 kg	65kA	66kA	265.480,-- €

## Leistungsebene 4000A-4850A

Filter Belastung		
2630 kW / 4000A	Bleibt der Filter zugeschaltet (Wirkung)	geht nach dieser Zeit in den BYPASS
2662 kW / 4050A		
2682 kW / 4080A		
2692 kW / 4095A	<b>75 Std</b>	
2705 kW / 4115A	<b>18 Std 45min</b>	
2718 kW / 4135A	<b>8 Std 20min</b>	
2731 kW / 4155A	<b>4 Std 41min 18sec</b>	
2761 kW / 4200A	<b>1 Std 55min 12sec</b>	
2794 kW / 4250A	<b>58min 48sec</b>	
2827 kW / 4300A	<b>35min 36sec</b>	

Mit zwei Leistungsschaltern

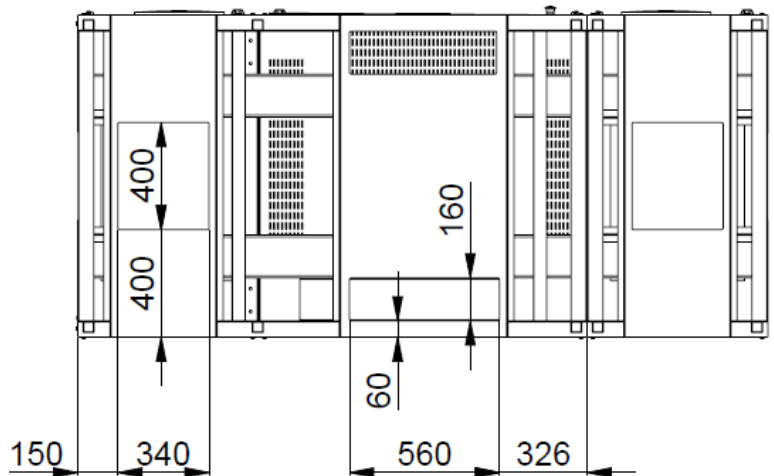
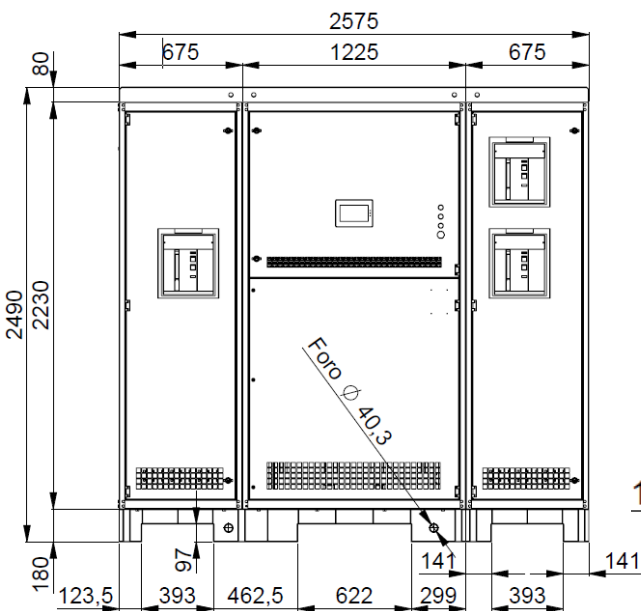
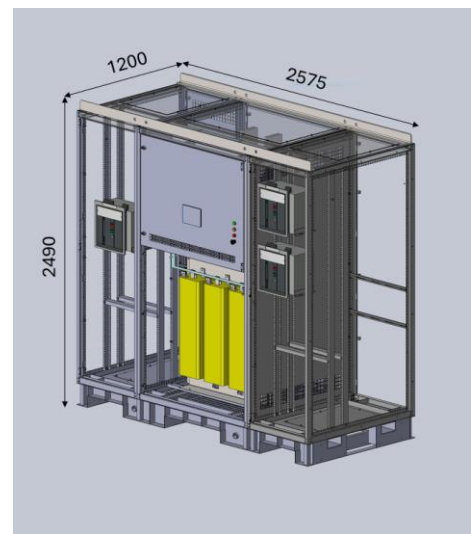



# Elektrischer Effizienzfilter *Schema mit 1 Transformator*

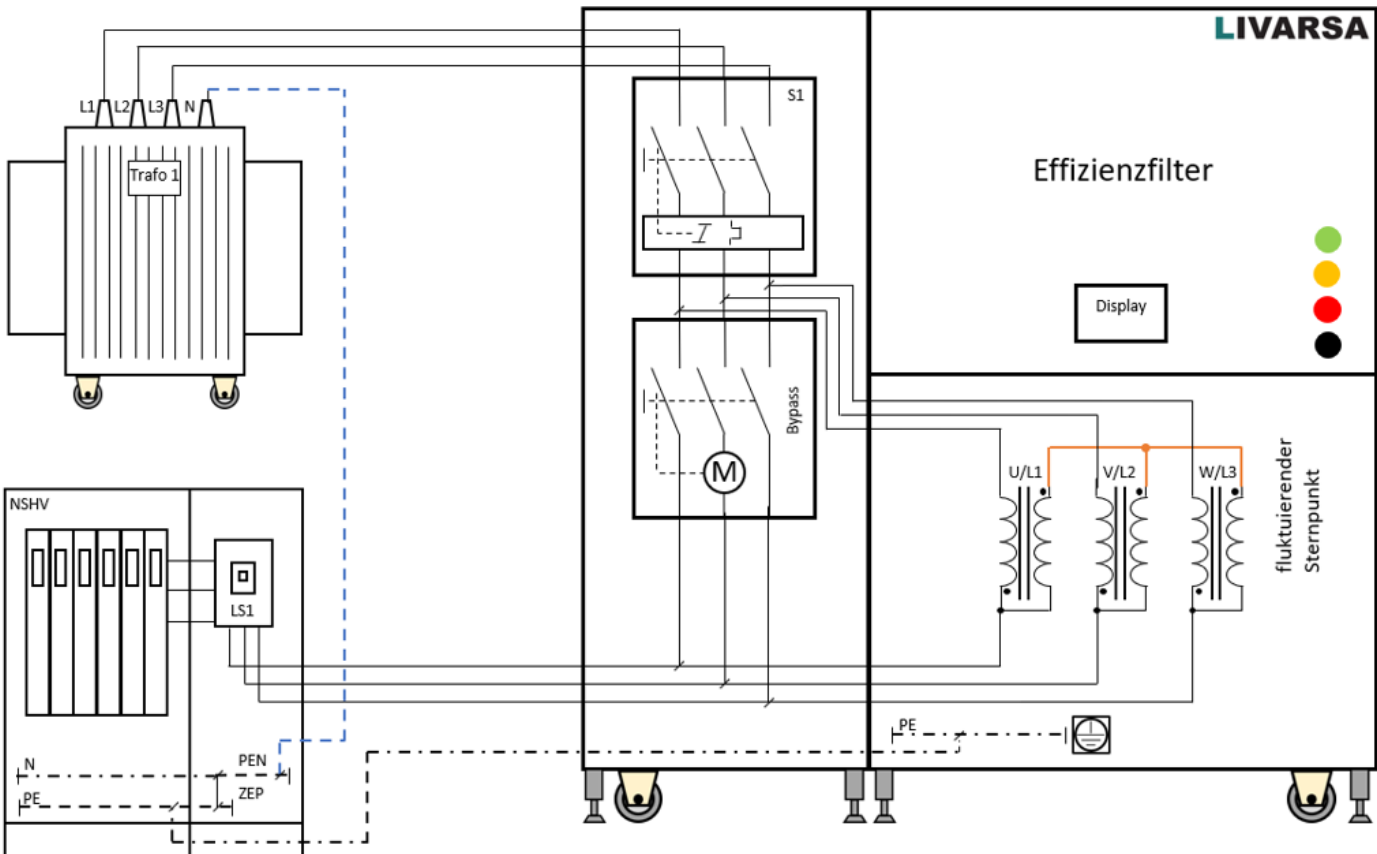
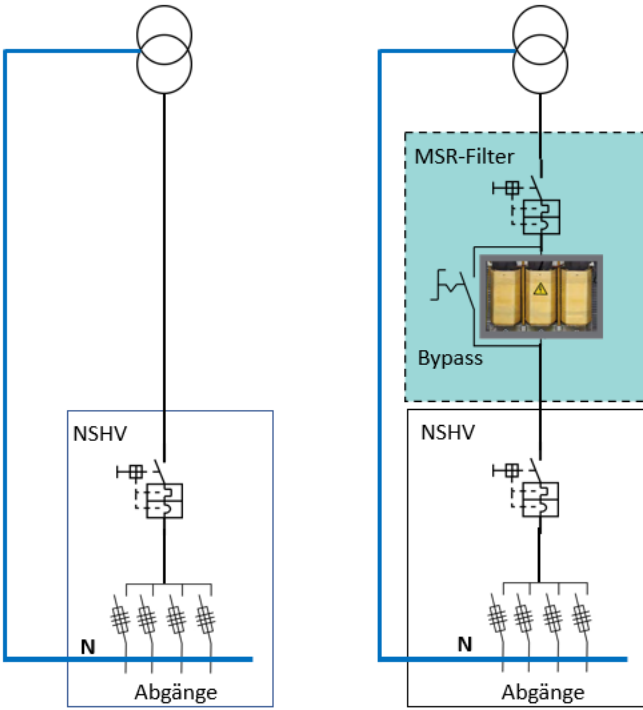

# Elektrischer Effizienzfilter *Schema mit 2 Transformatoren*

Ohne Effizienzfilter

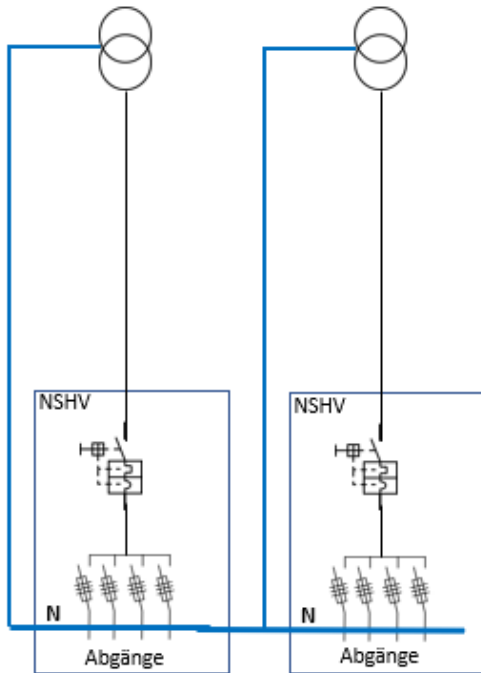

Mit Effizienzfilter

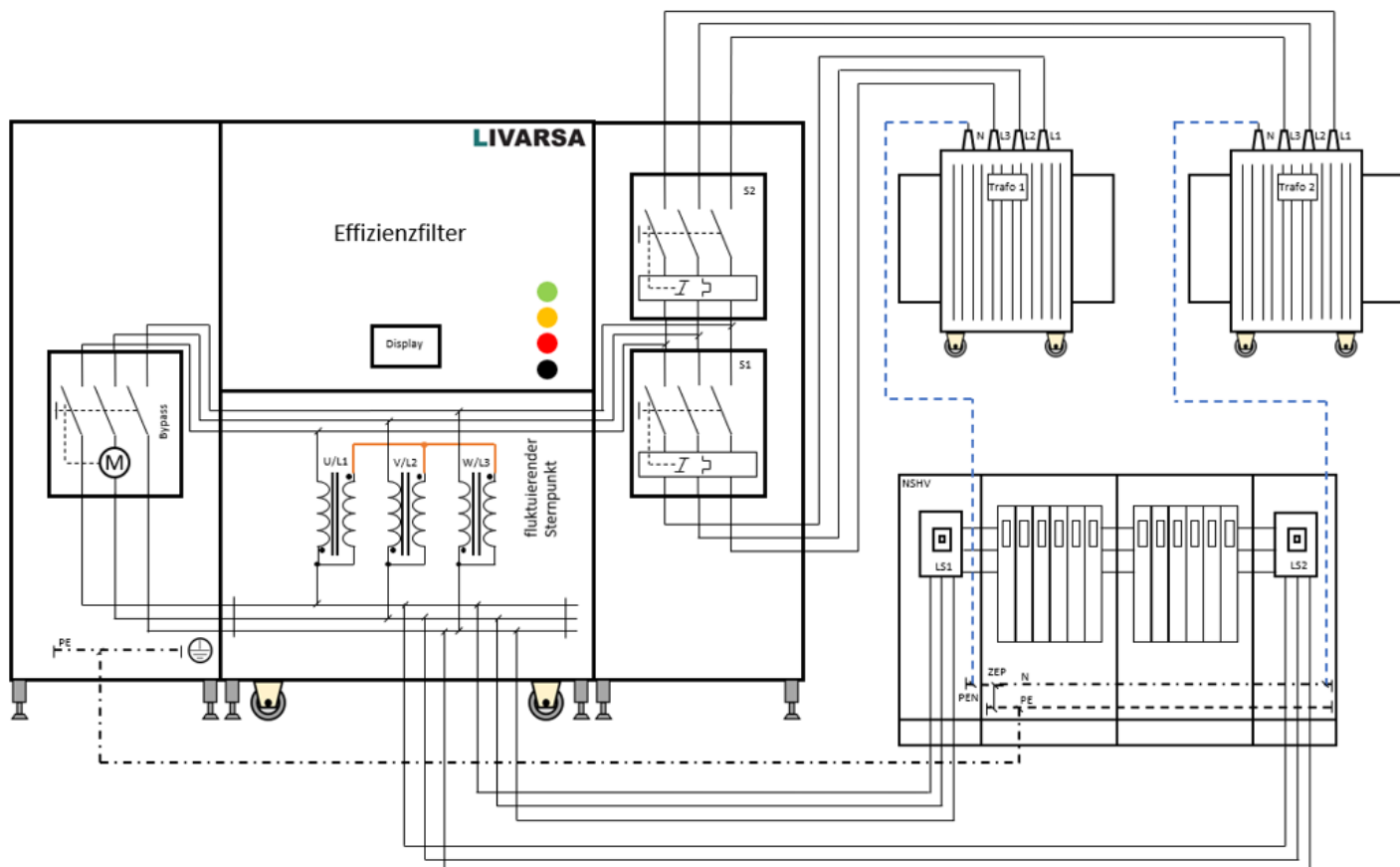
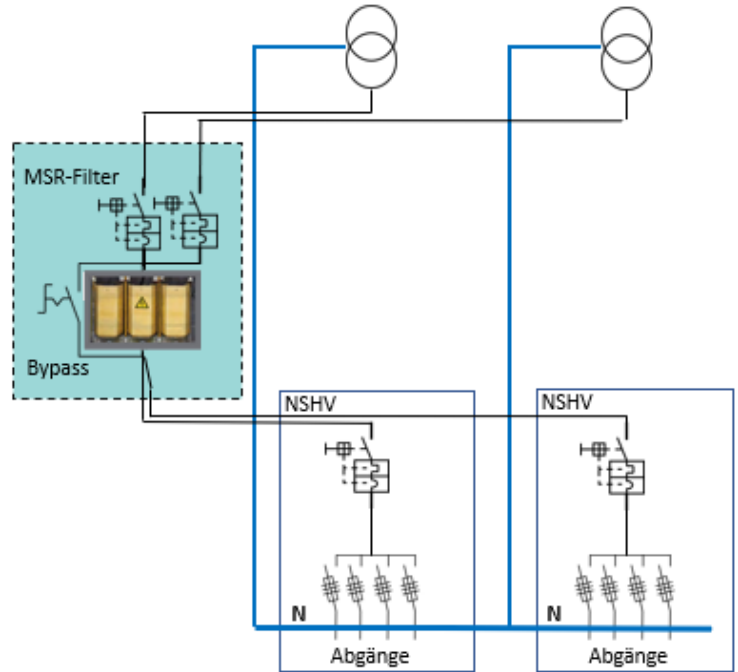

# Elektrischer Effizienzfilter *Schema mit 3 Transformatoren*

Ohne Effizienzfilter

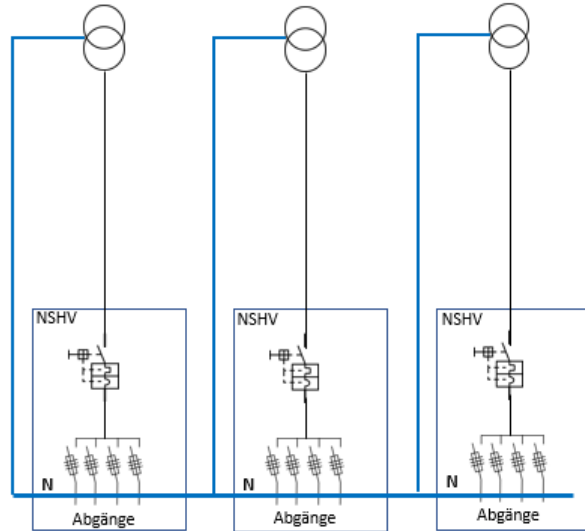

Mit Effizienzfilter

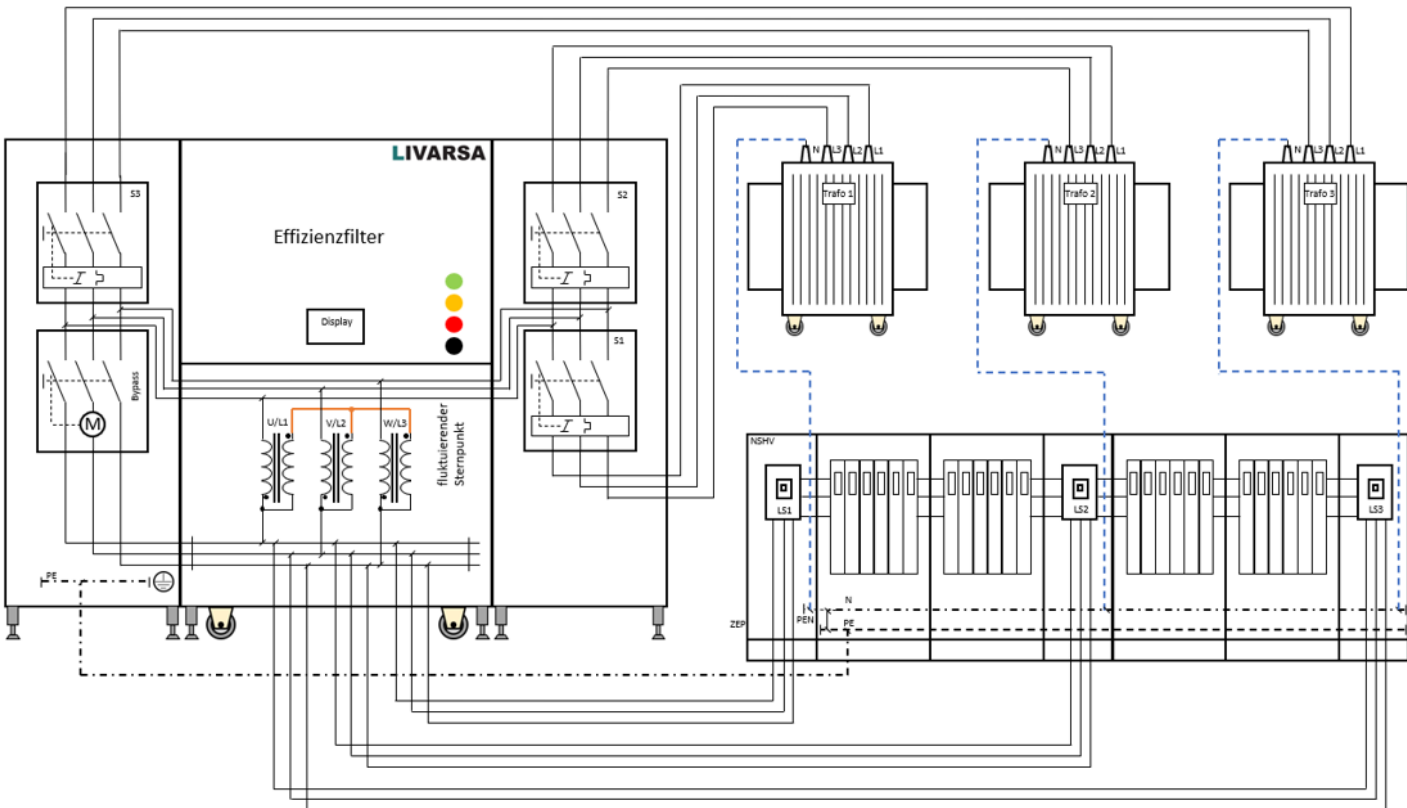
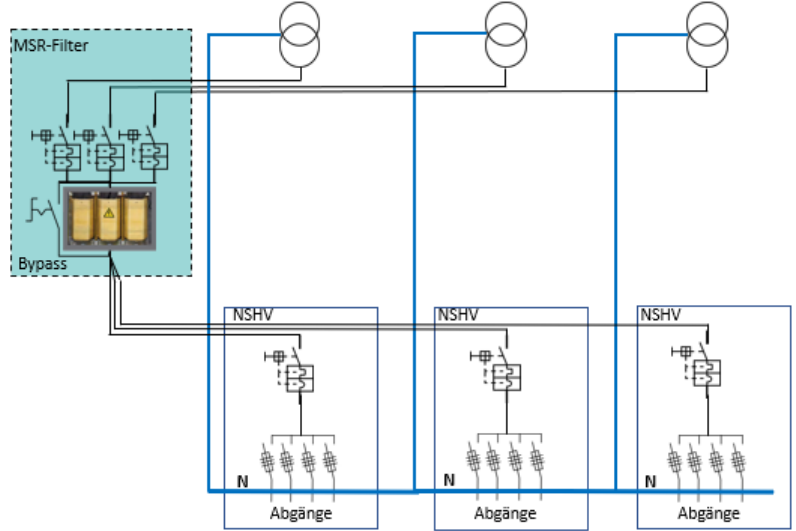

# E-Container für den Effizienzfilter





# E-Container Model- EXPO 2438

Artikel-Nr	Farbe	Maße B/L/H	Gewicht	Listenpreis o. MwSt.
EXPO2438	RAL 9002	2438/2438/2500	860 kg	9.360,-- €

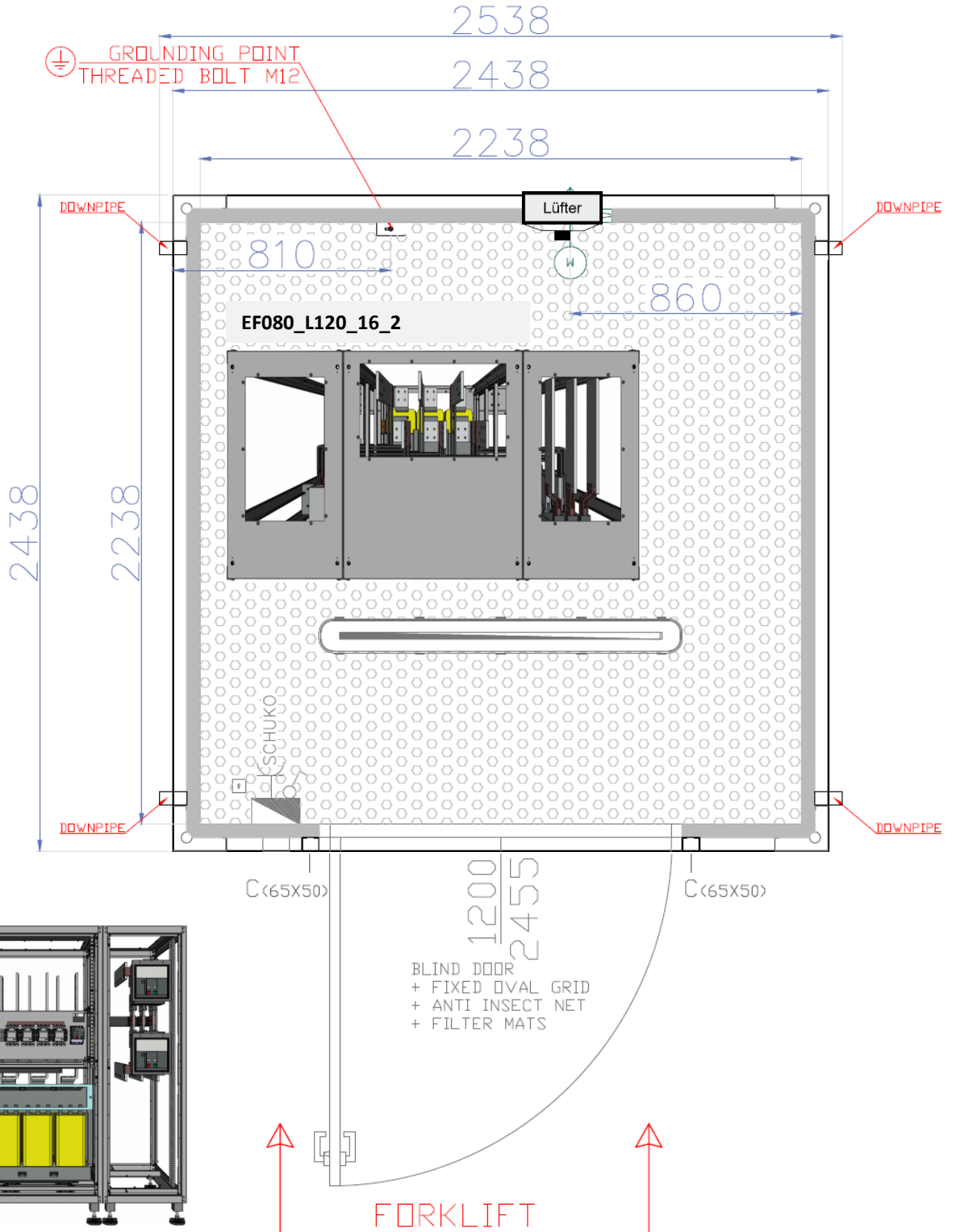

# E-Container Model- EXPO 2438

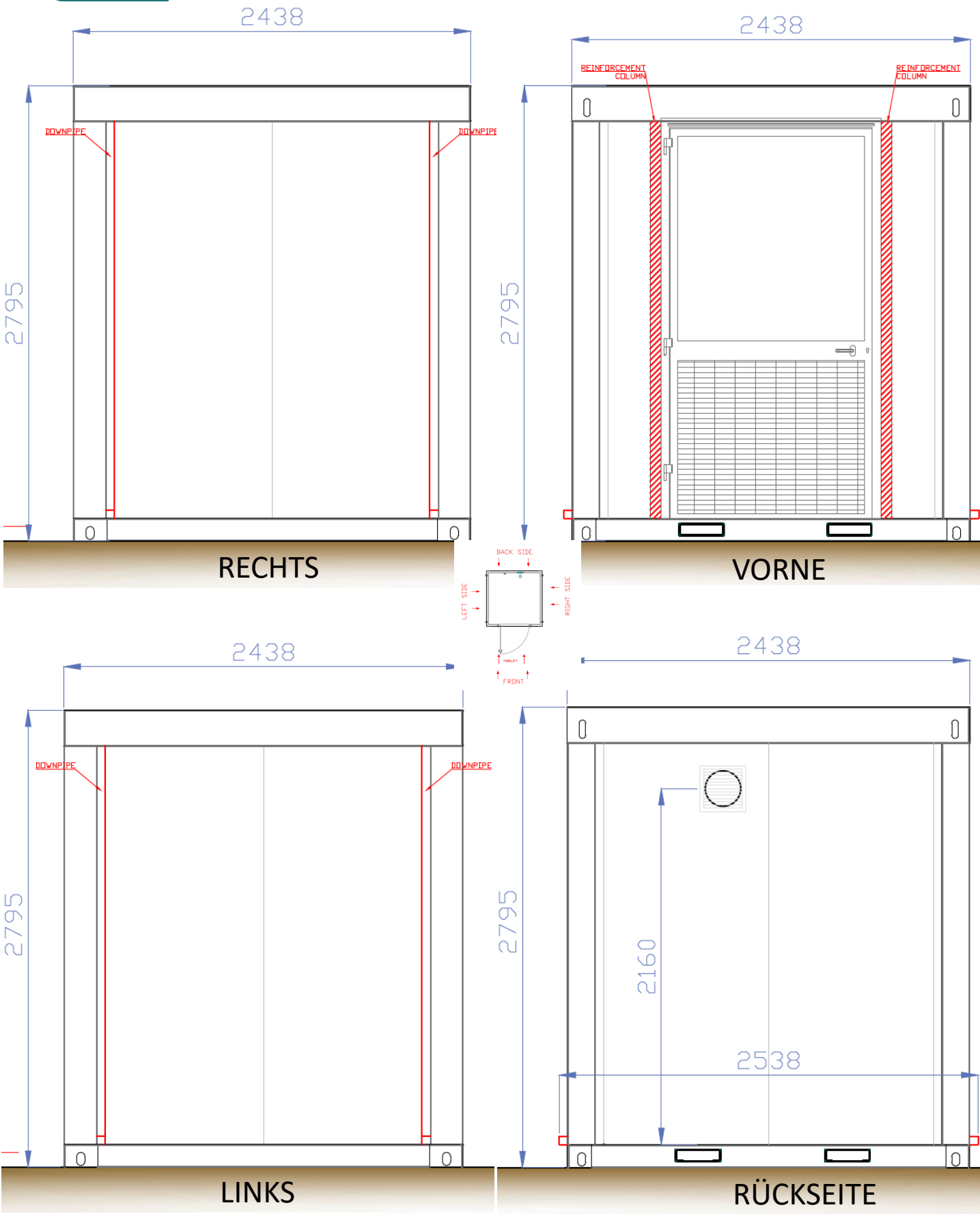

# E-Container Model- EXPO 2438

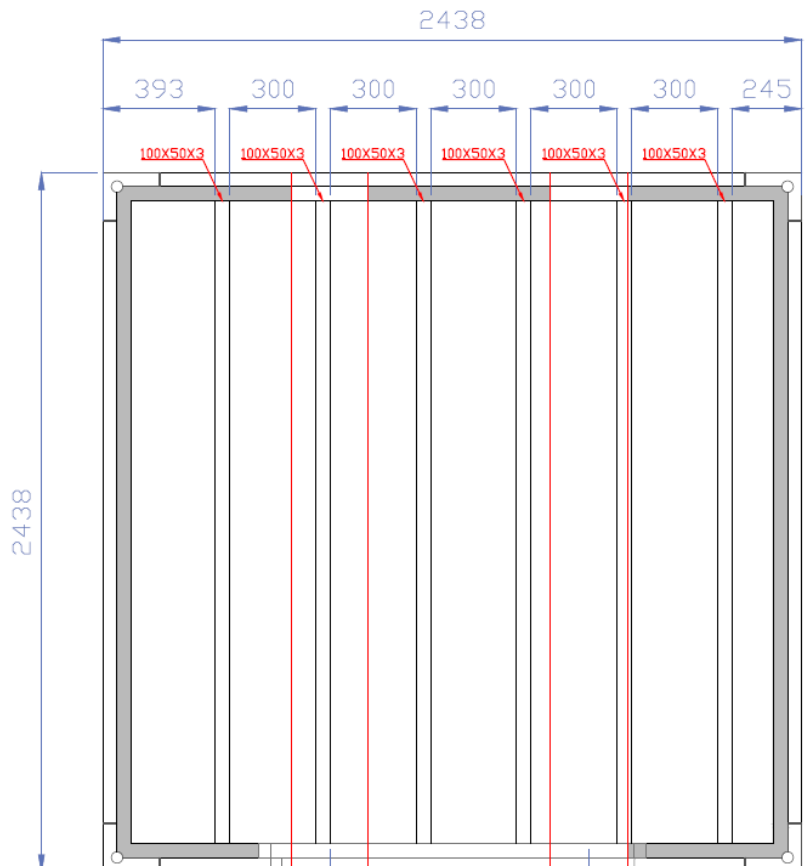
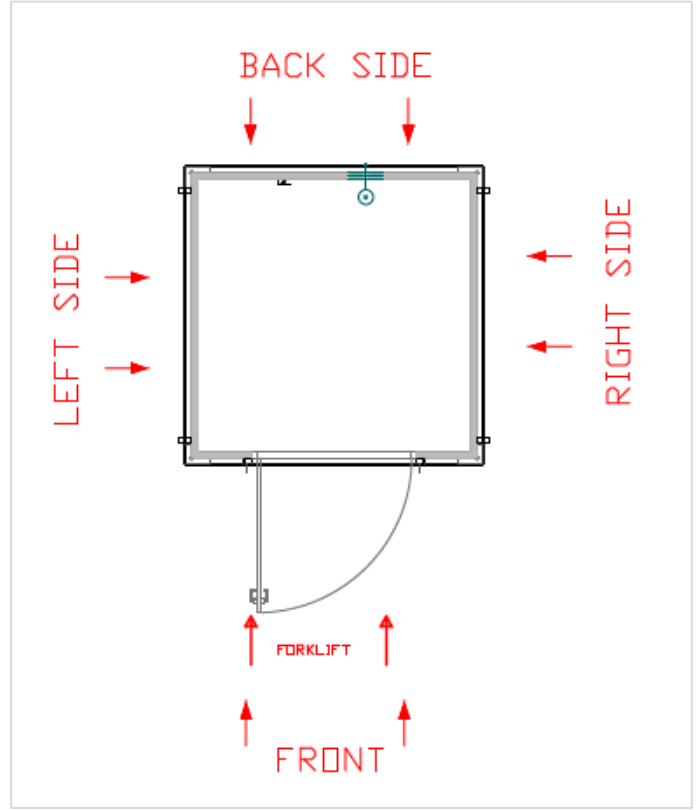
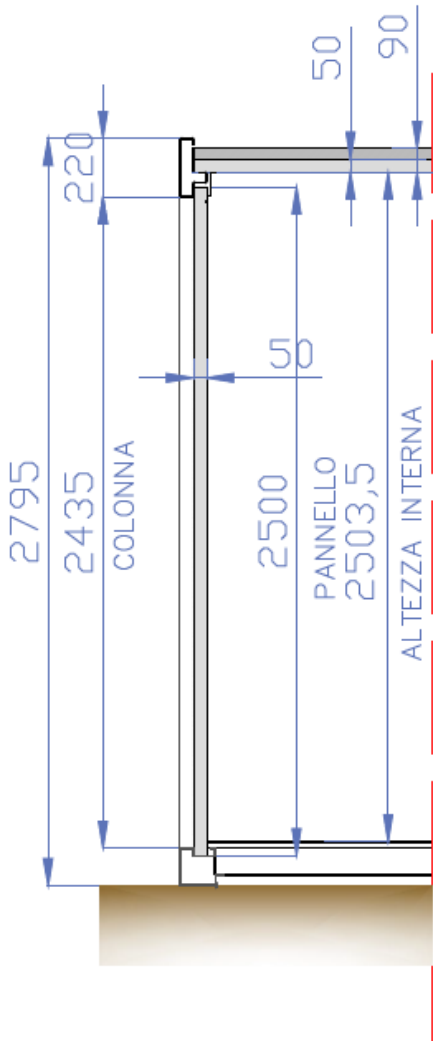



## BEISPIELE VARIANTE

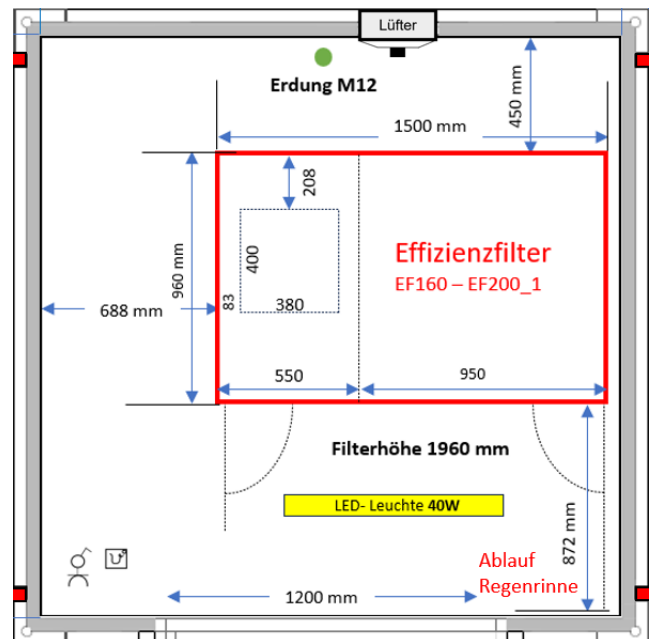
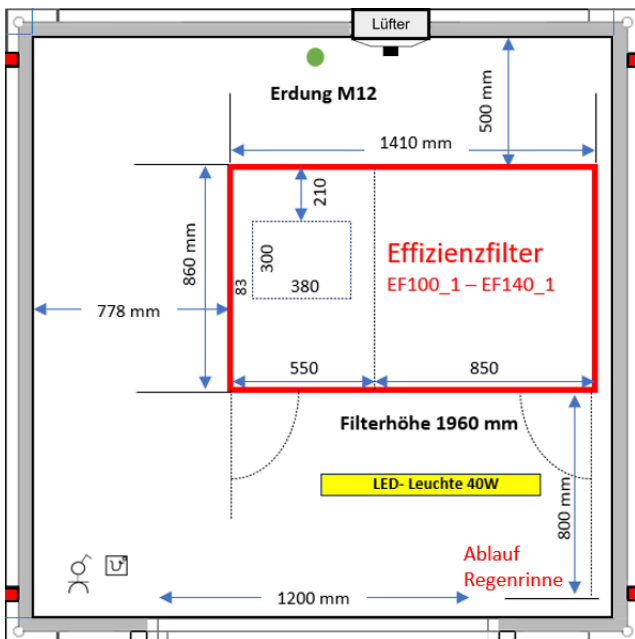
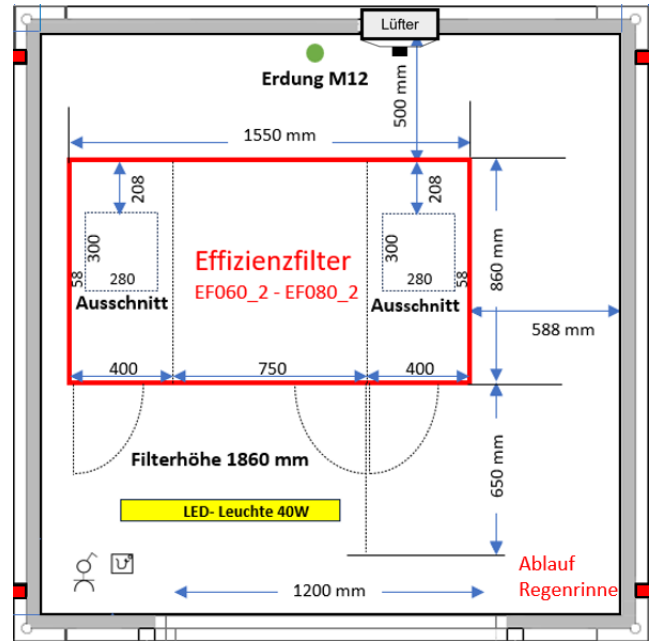
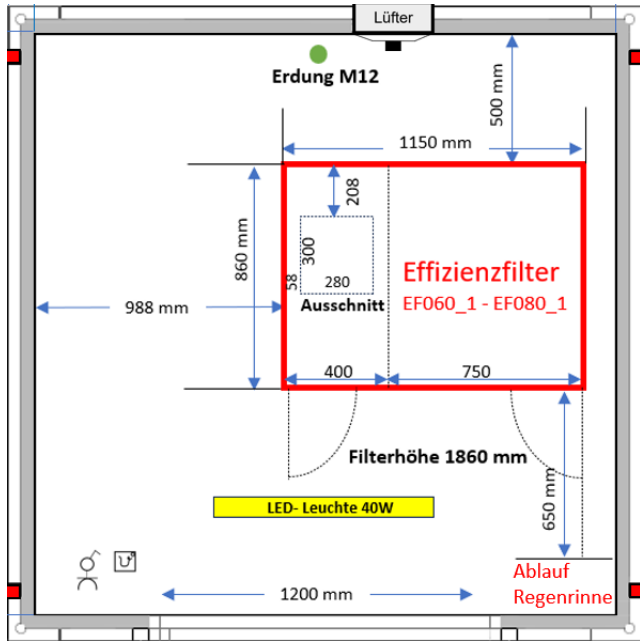

# E-Container Model- EXPO 3000

Artikel-Nr	Farbe	Maße B/L/H	Gewicht	Listenpreis o. MwSt.
EXPO3000	RAL 9002	3000/2438/2500	1100 kg	11.700,-- €

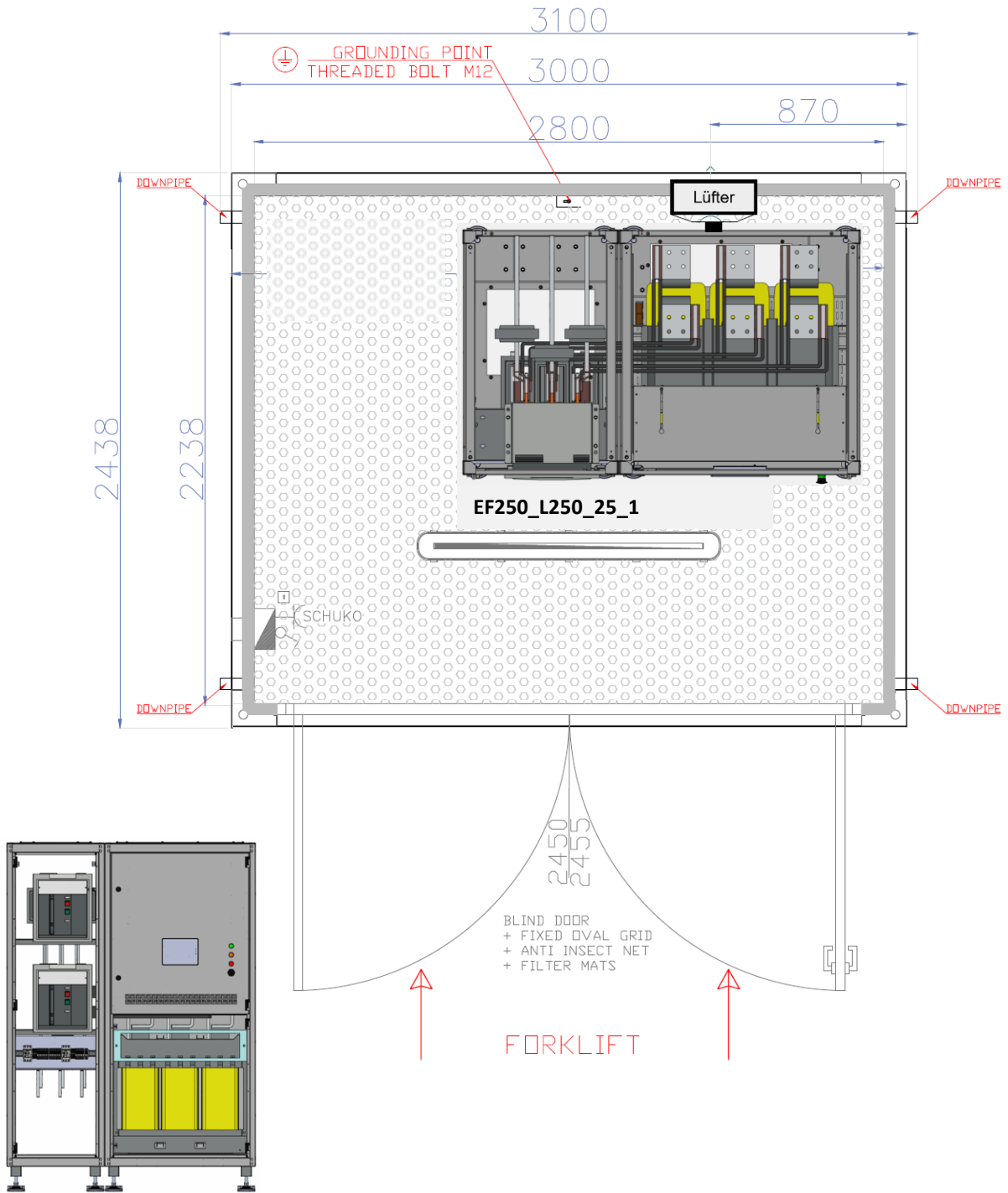

# E-Container Model- EXPO 3000

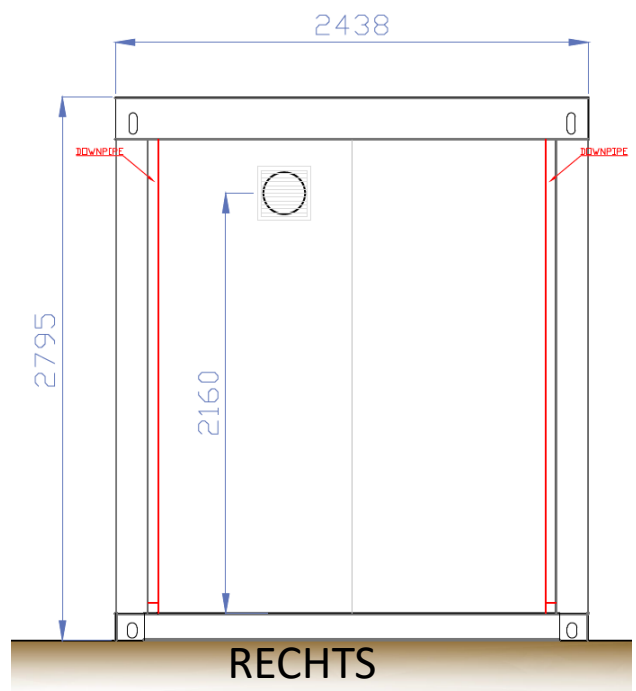
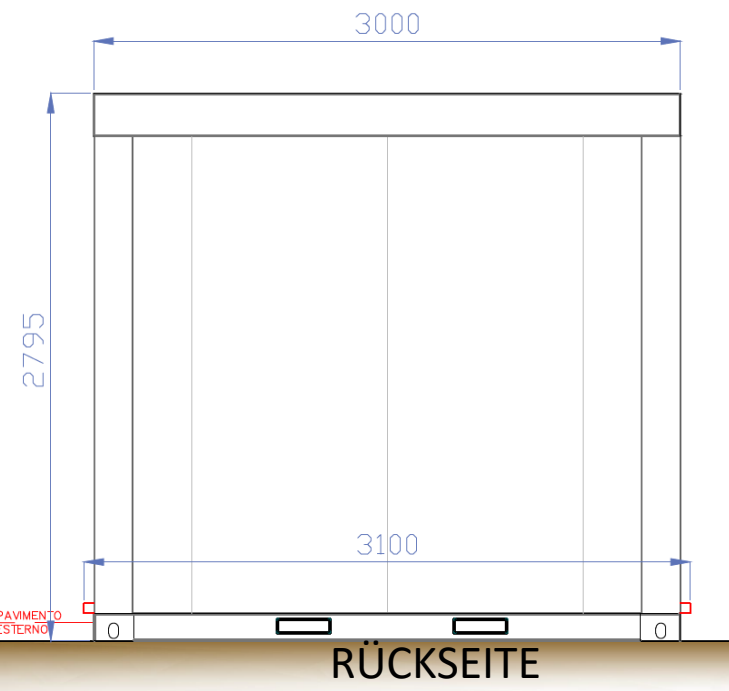
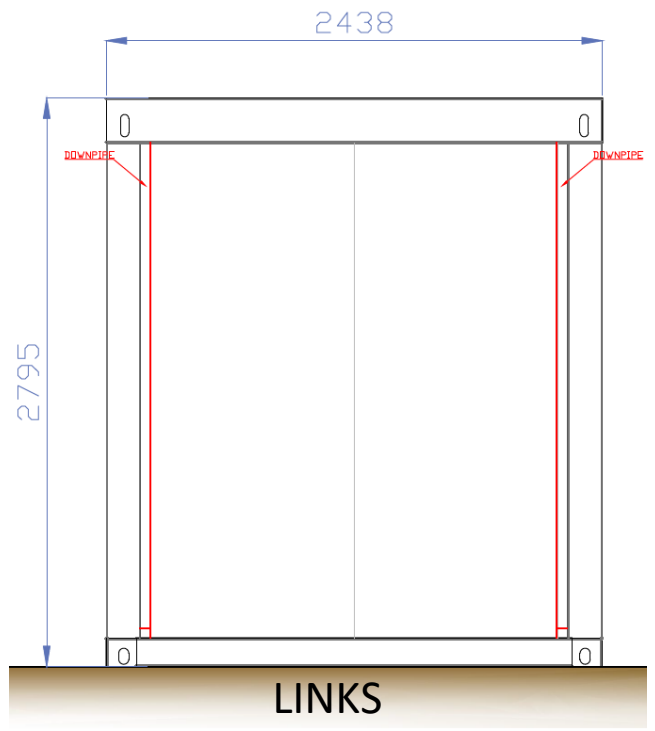
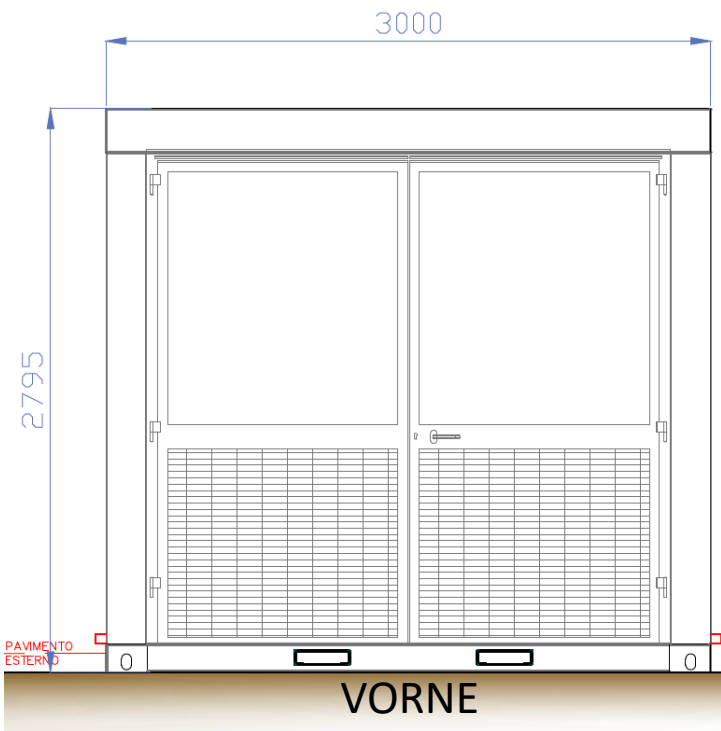

# E-Container Model- EXPO 3000

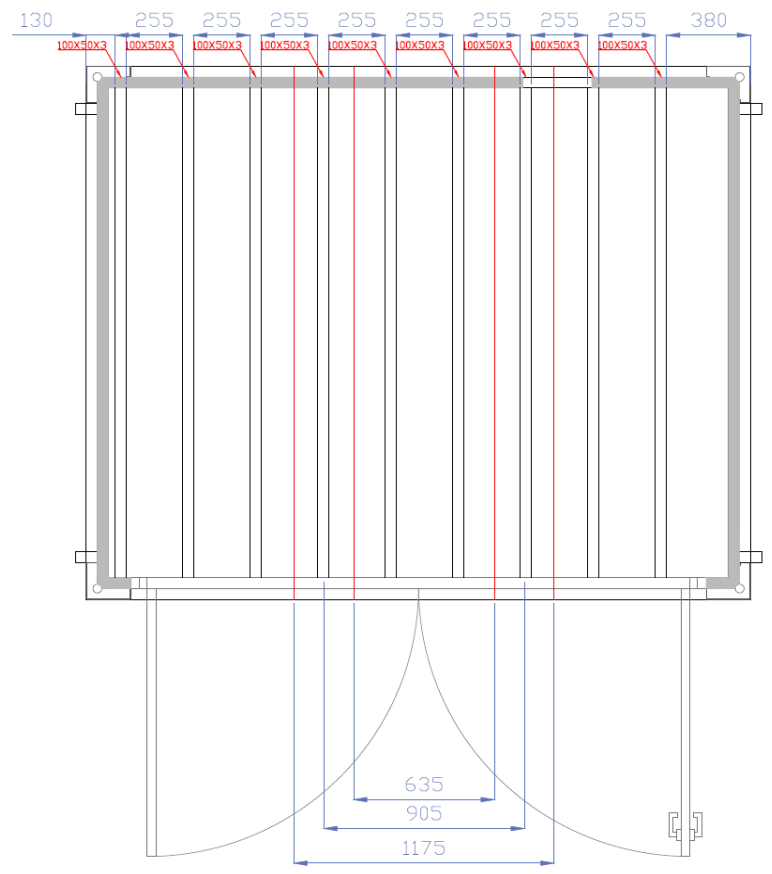
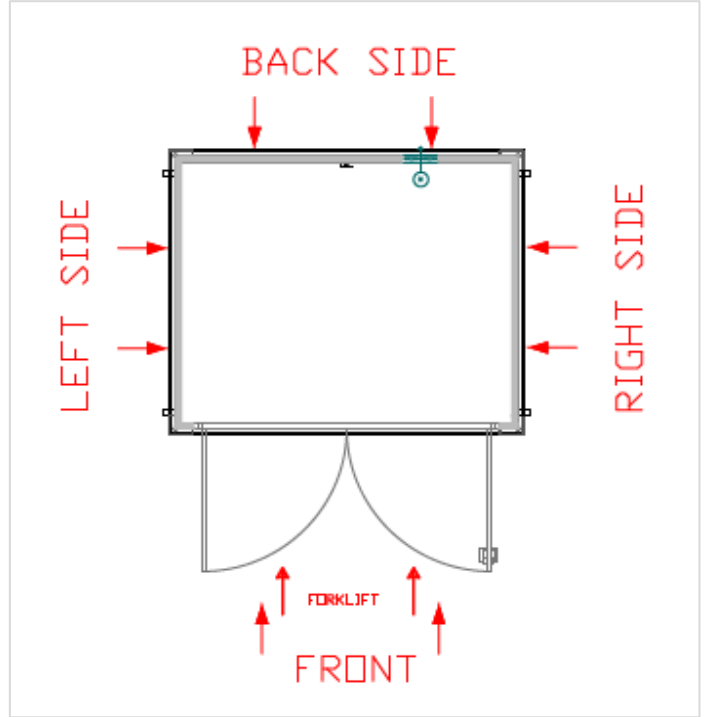
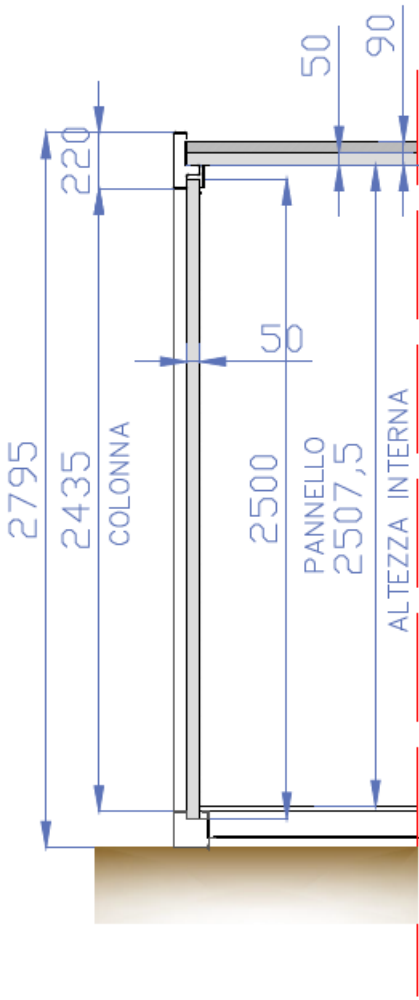

# E-Container Model- EXPO 3000

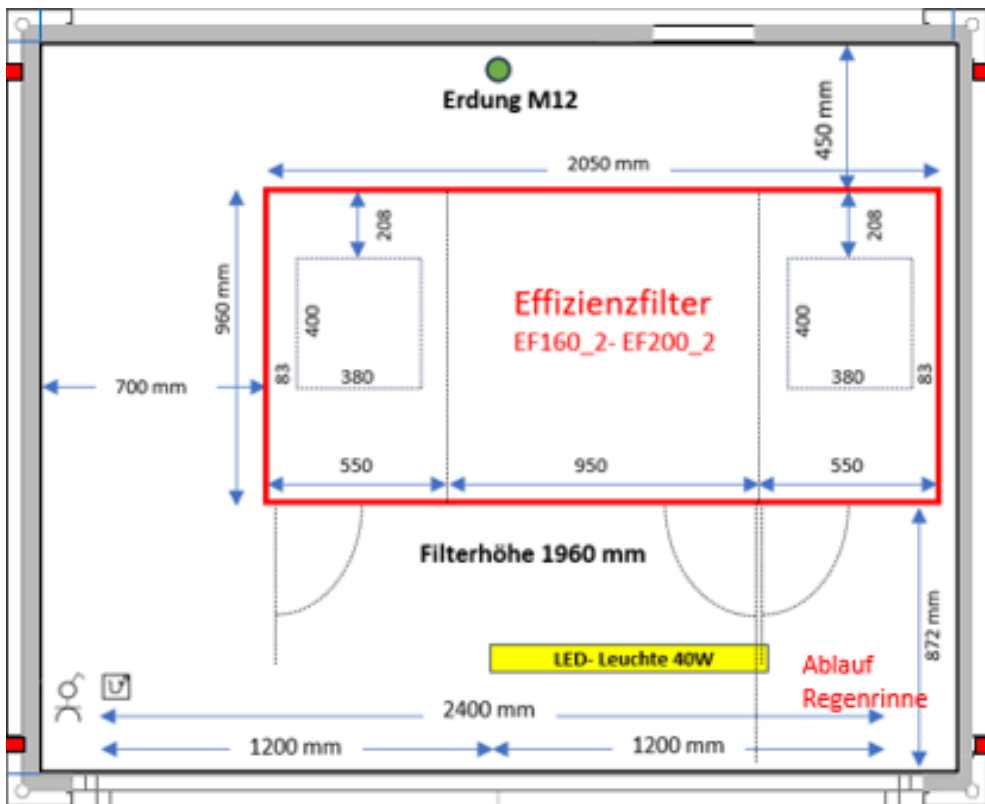
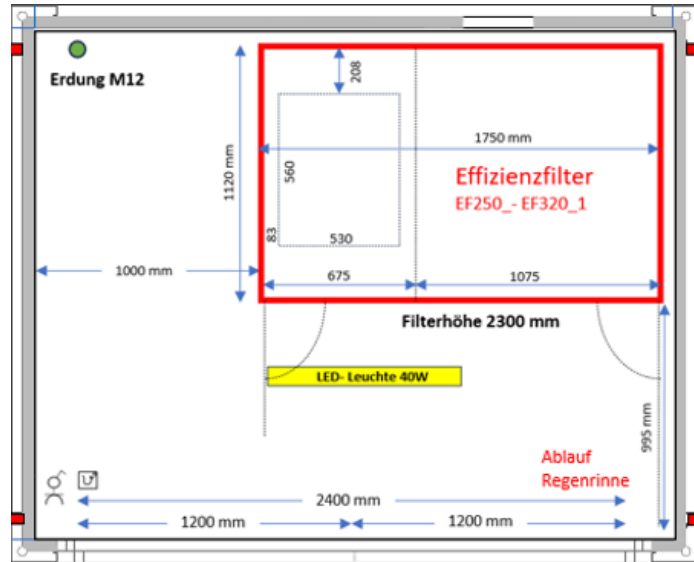
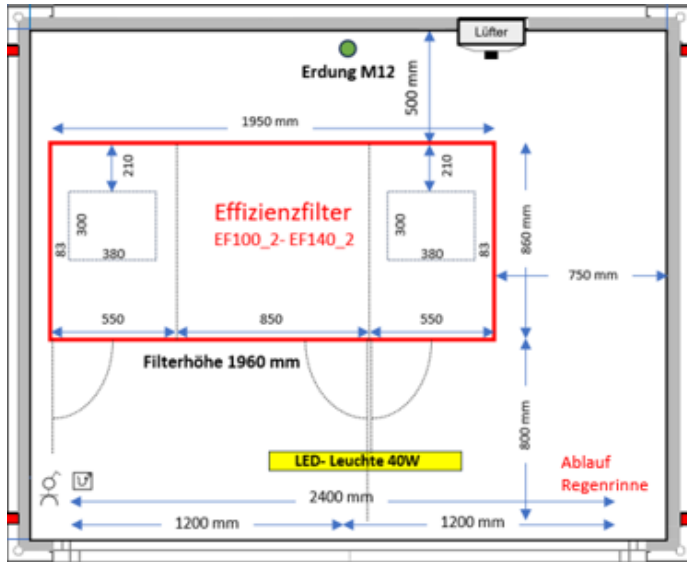

# E-Container Model- EXPO 4000

Artikel-Nr	Farbe	Maße B/L/H	Gewicht	Listenpreis o. MwSt.
EXPO4000	RAL 9002	4000/2438/2500	1200 kg	12.885,- €

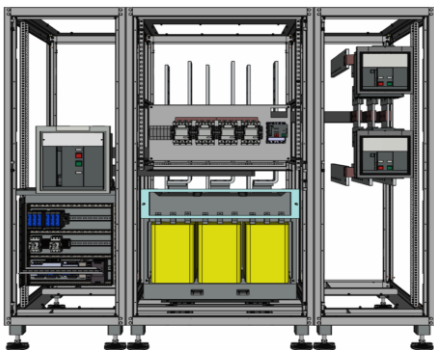
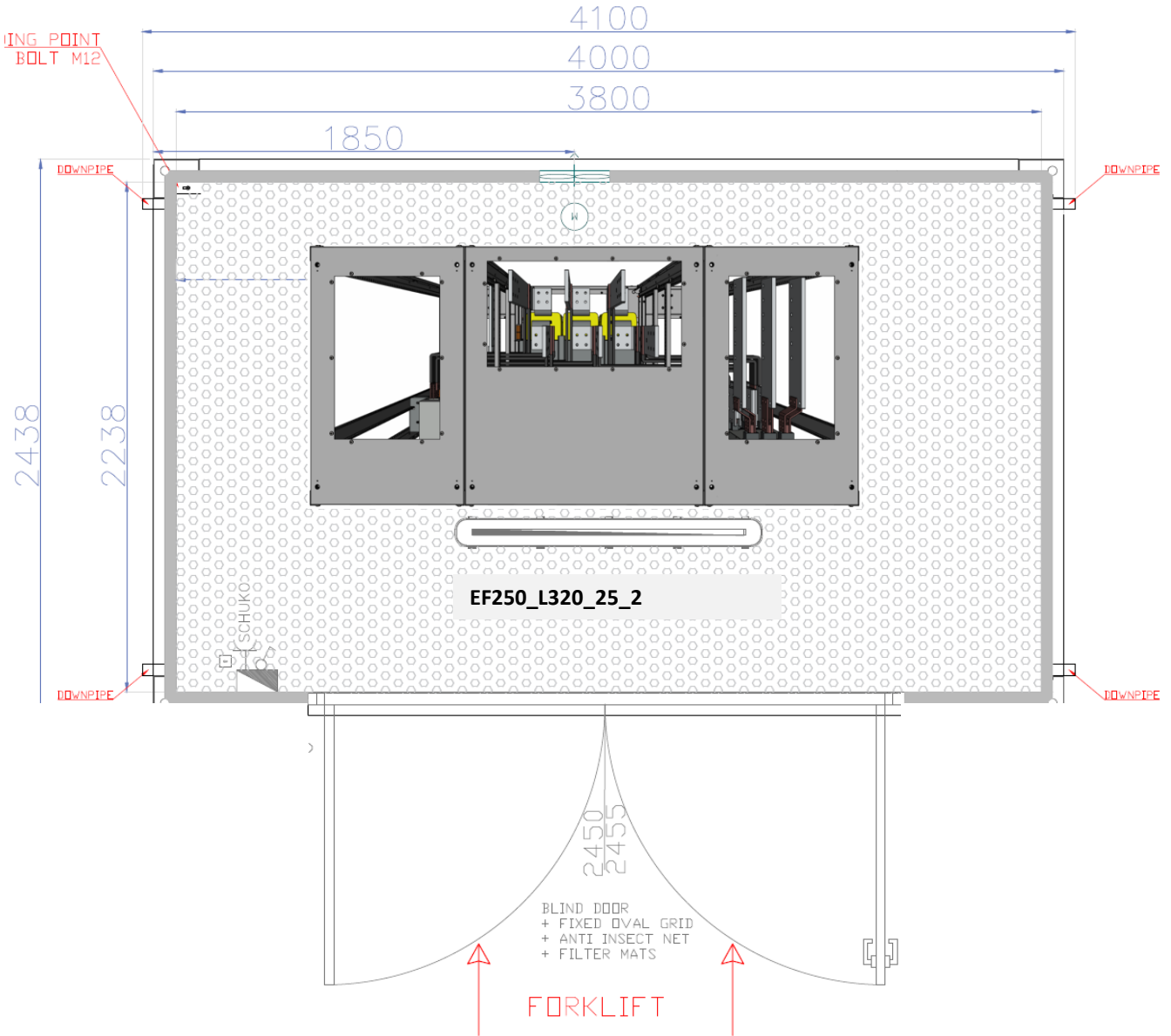

# E-Container Model- EXPO 4000

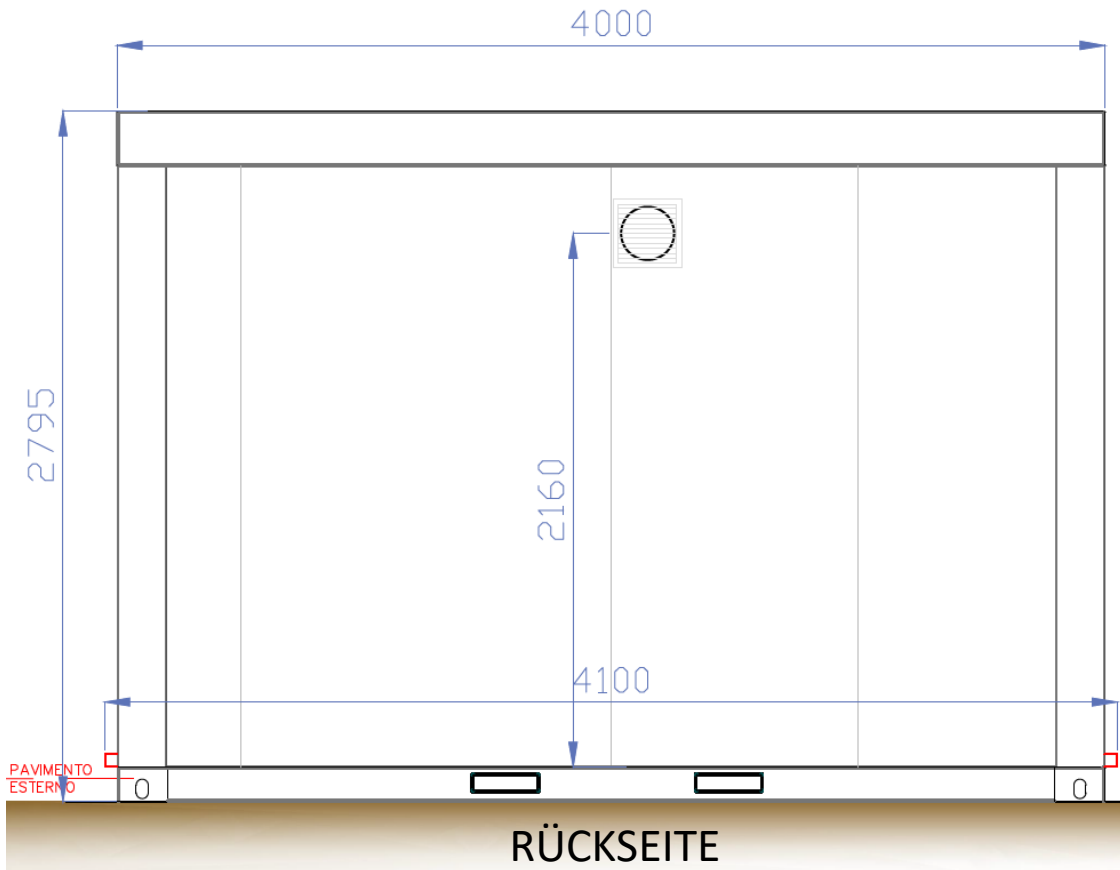
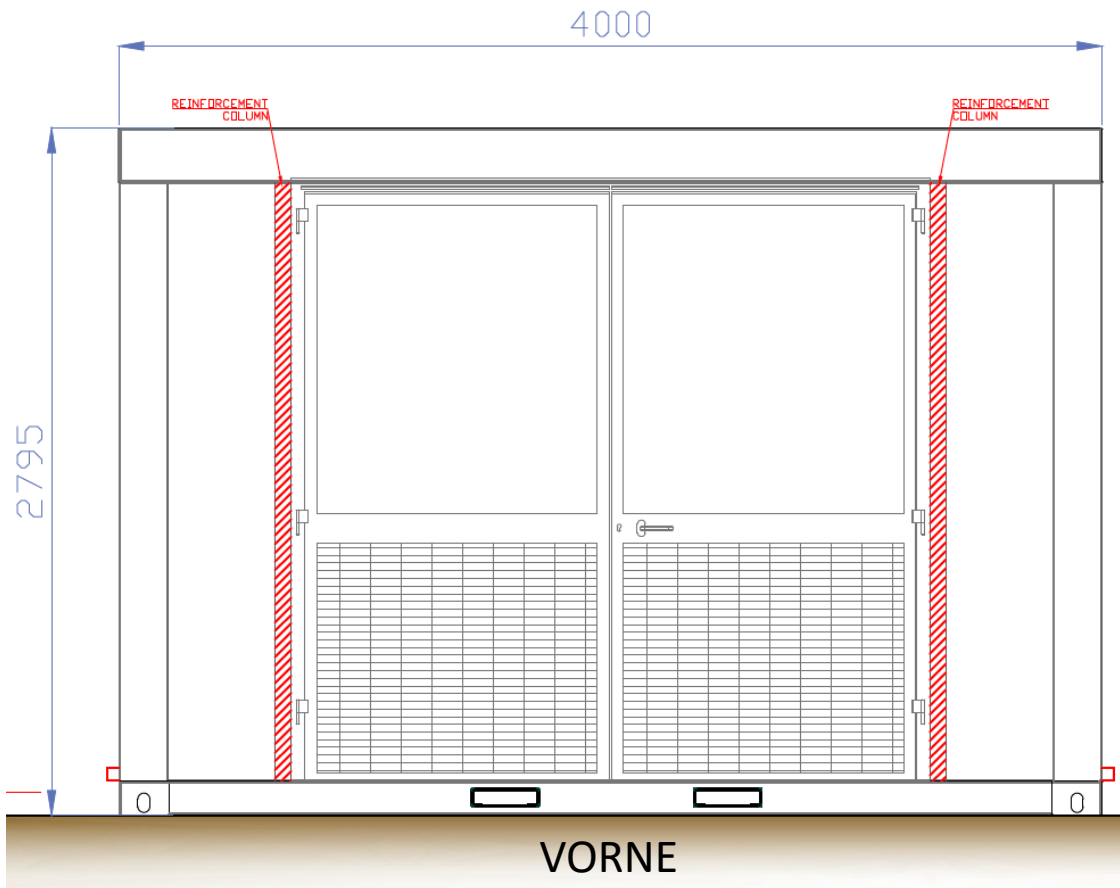

# E-Container Model- EXPO 4000

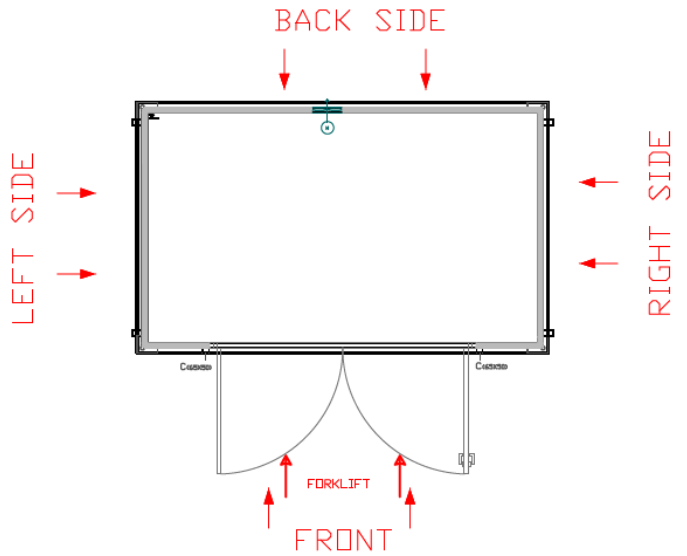
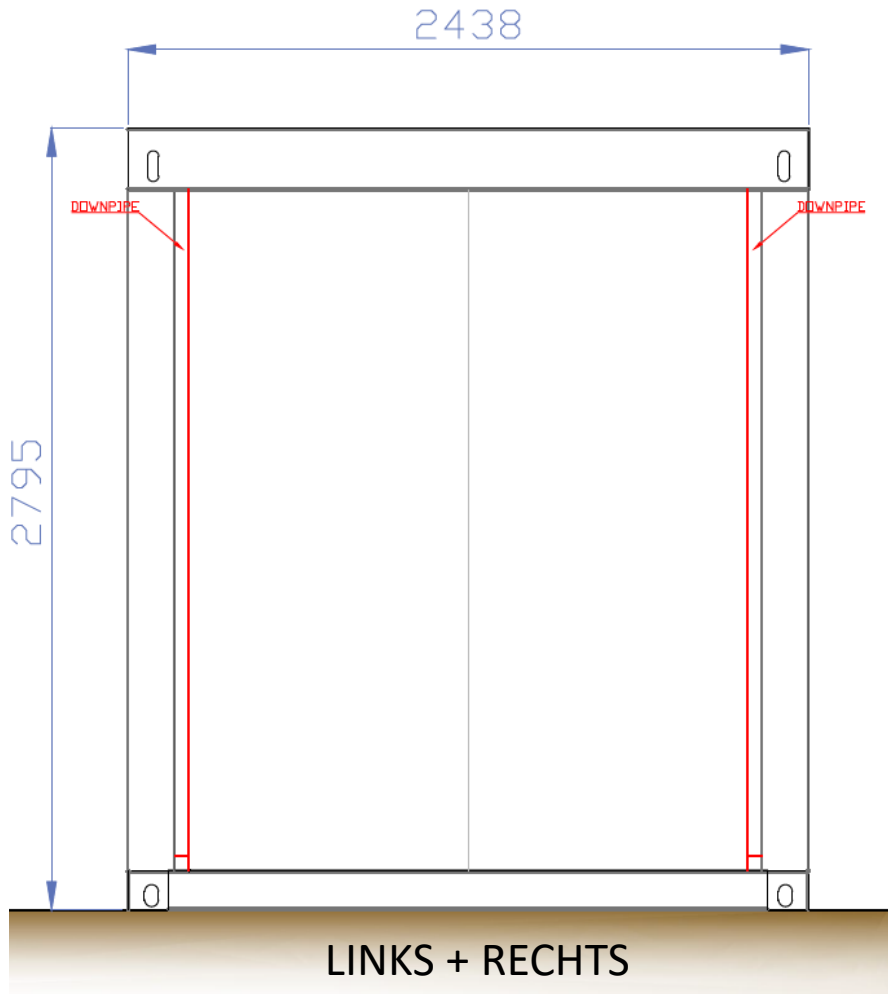
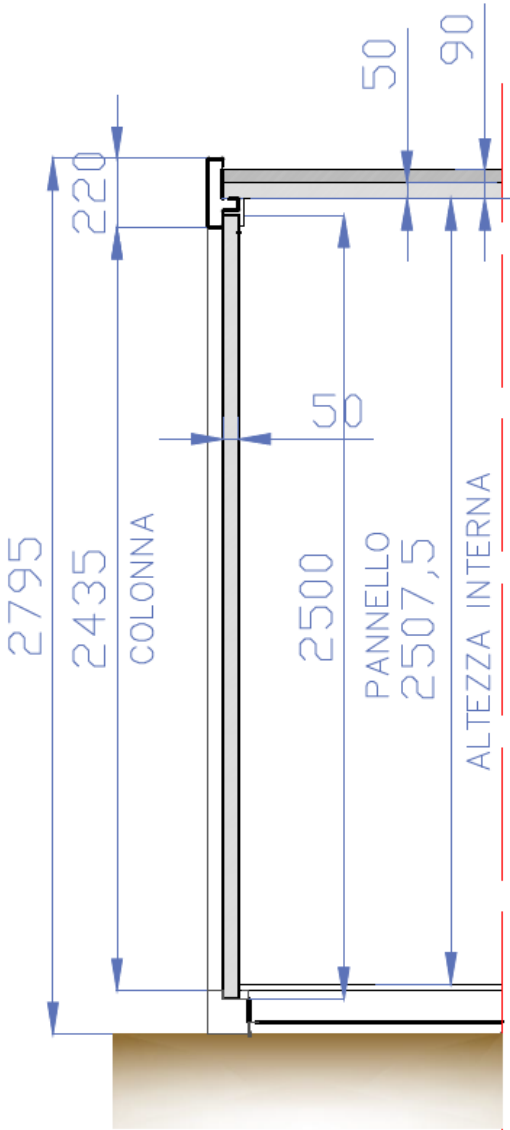



# E-Container Model- EXPO 4000

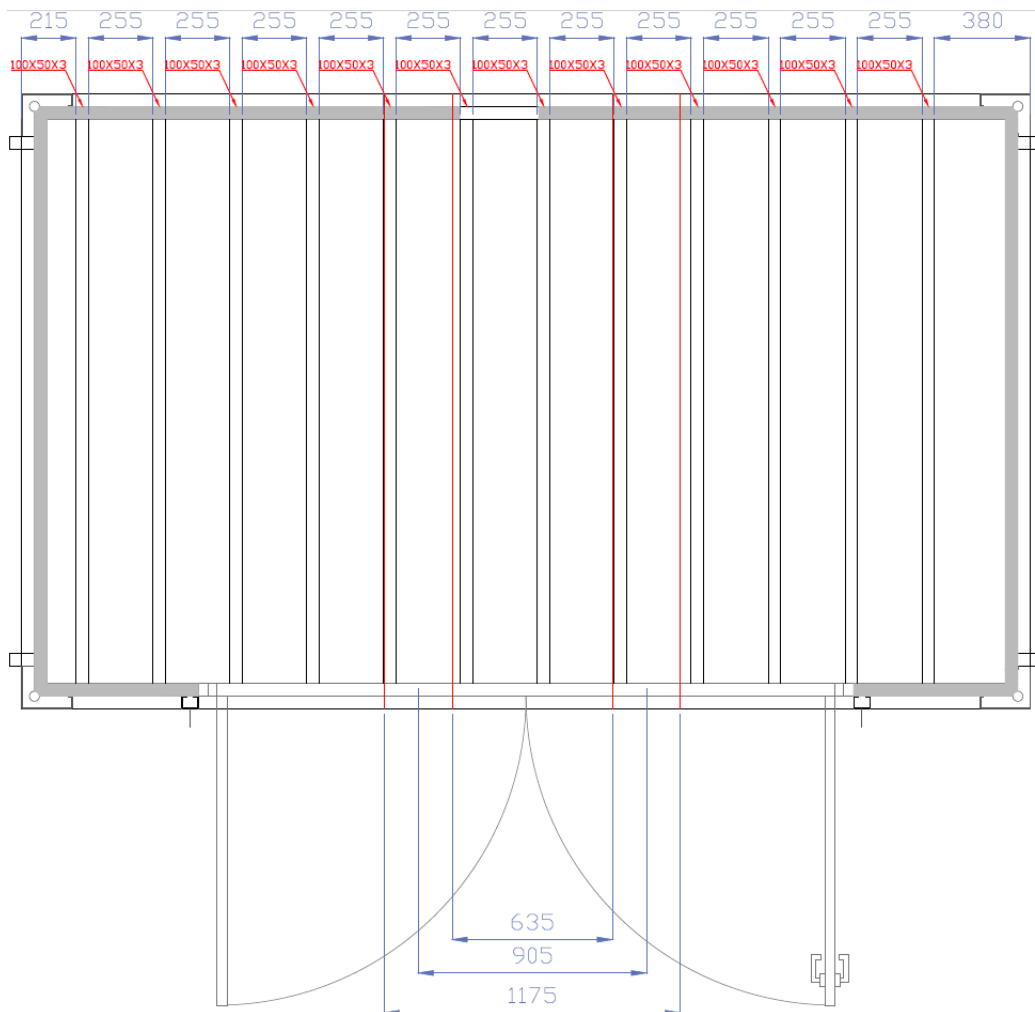
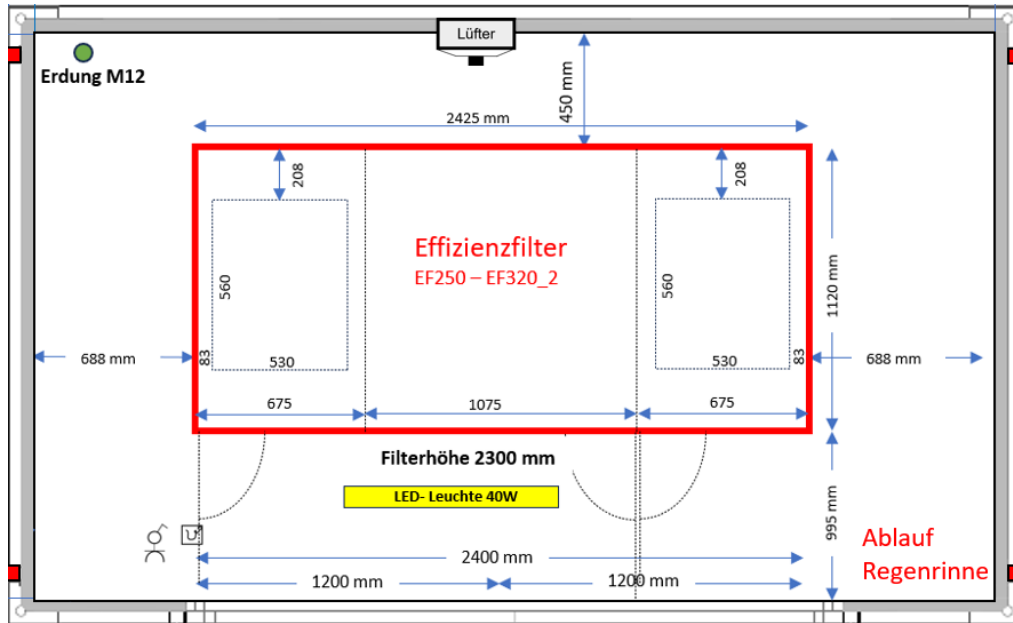

# E-Container Model- EXPO 5000

Artikel-Nr.	Farbe	Maße B/L/H	Gewicht	Listenpreis o. MwSt.
EXPO5000	RAL 9002	5000/2438/2500	1400 kg	17.474,-- €

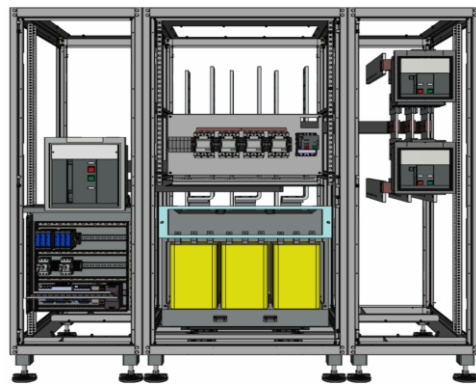
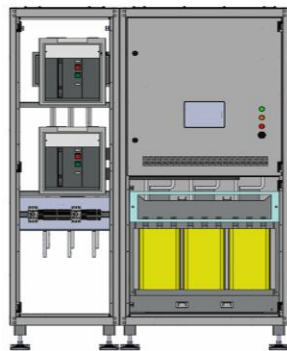
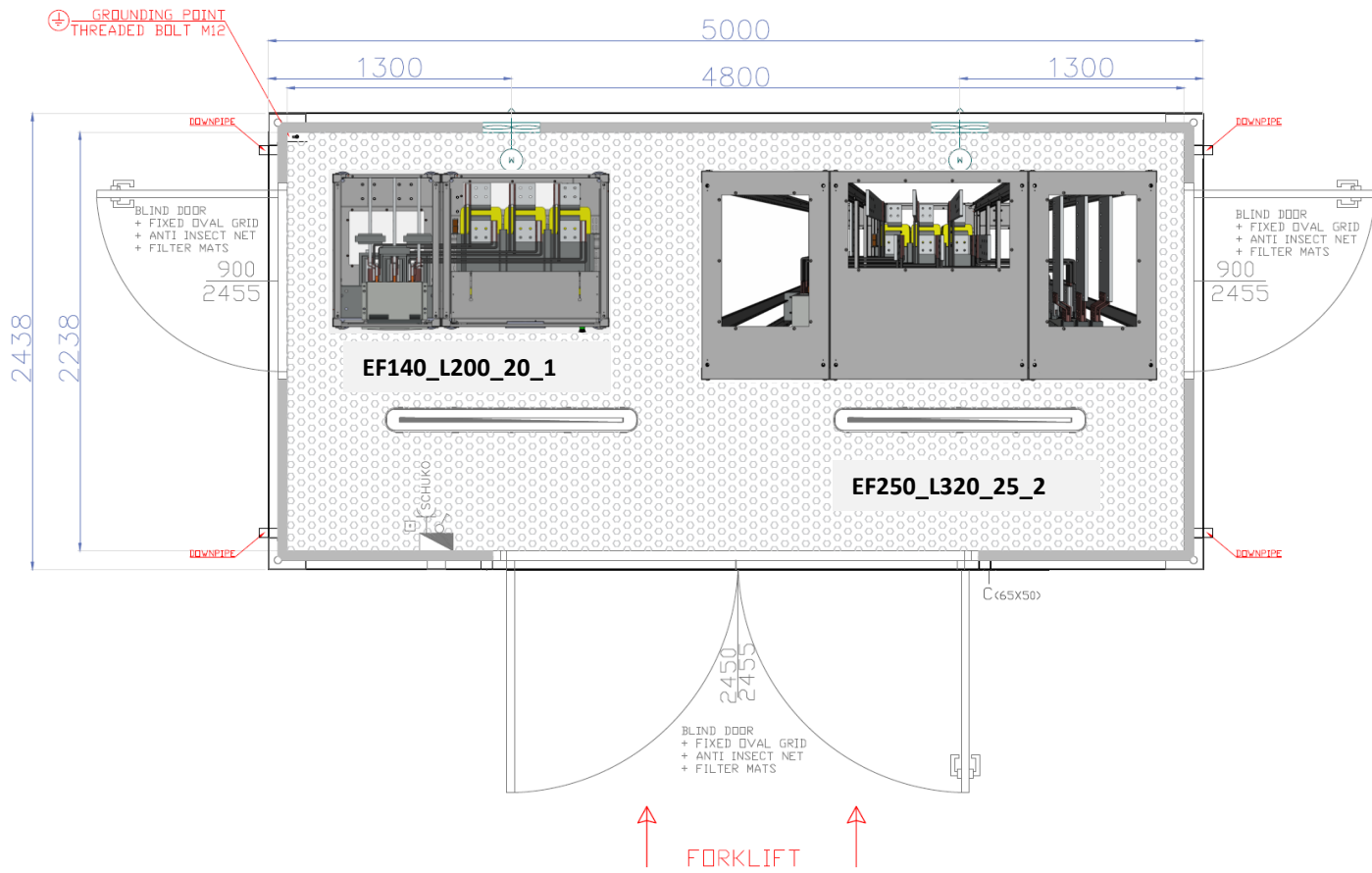

# E-Container Model- EXPO 5000

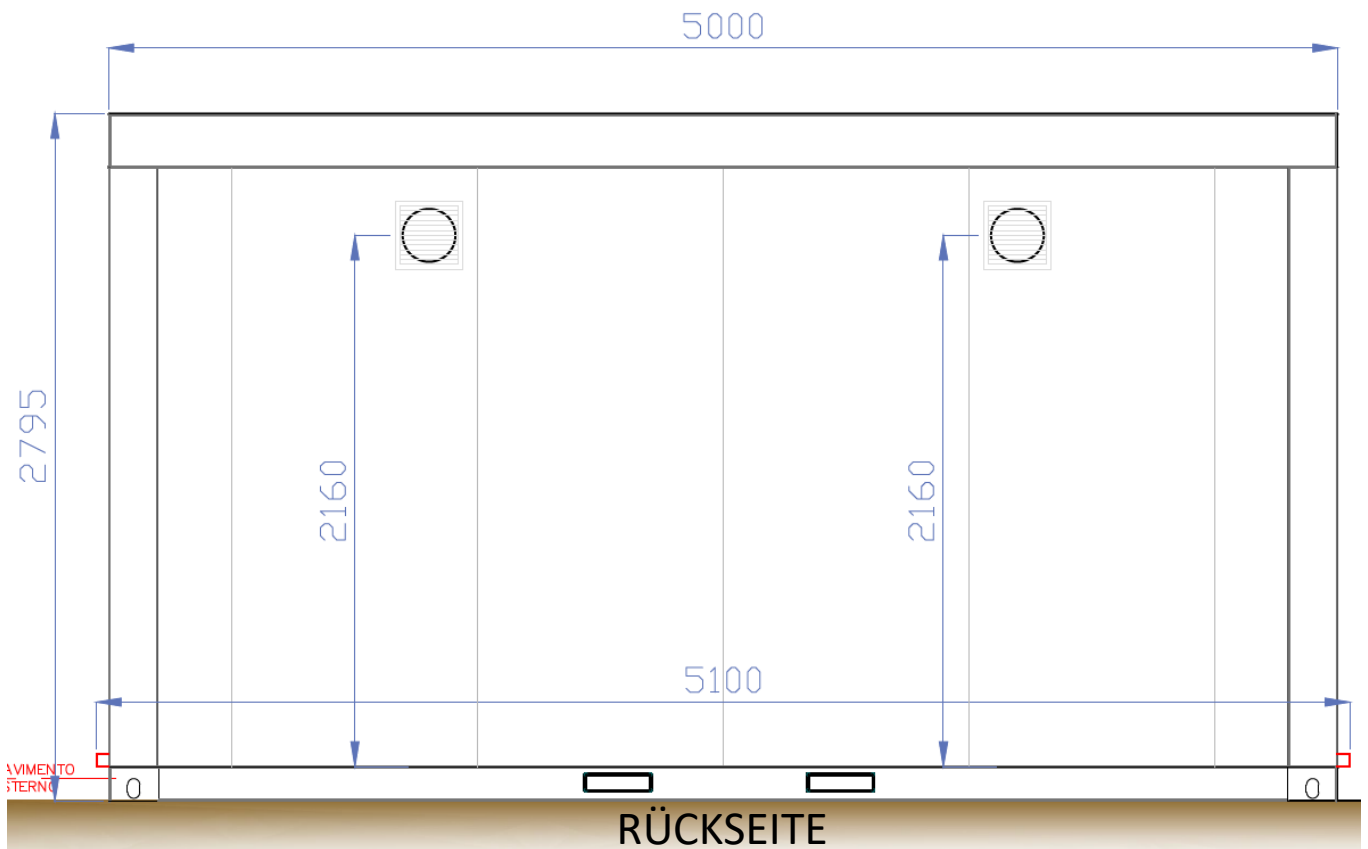
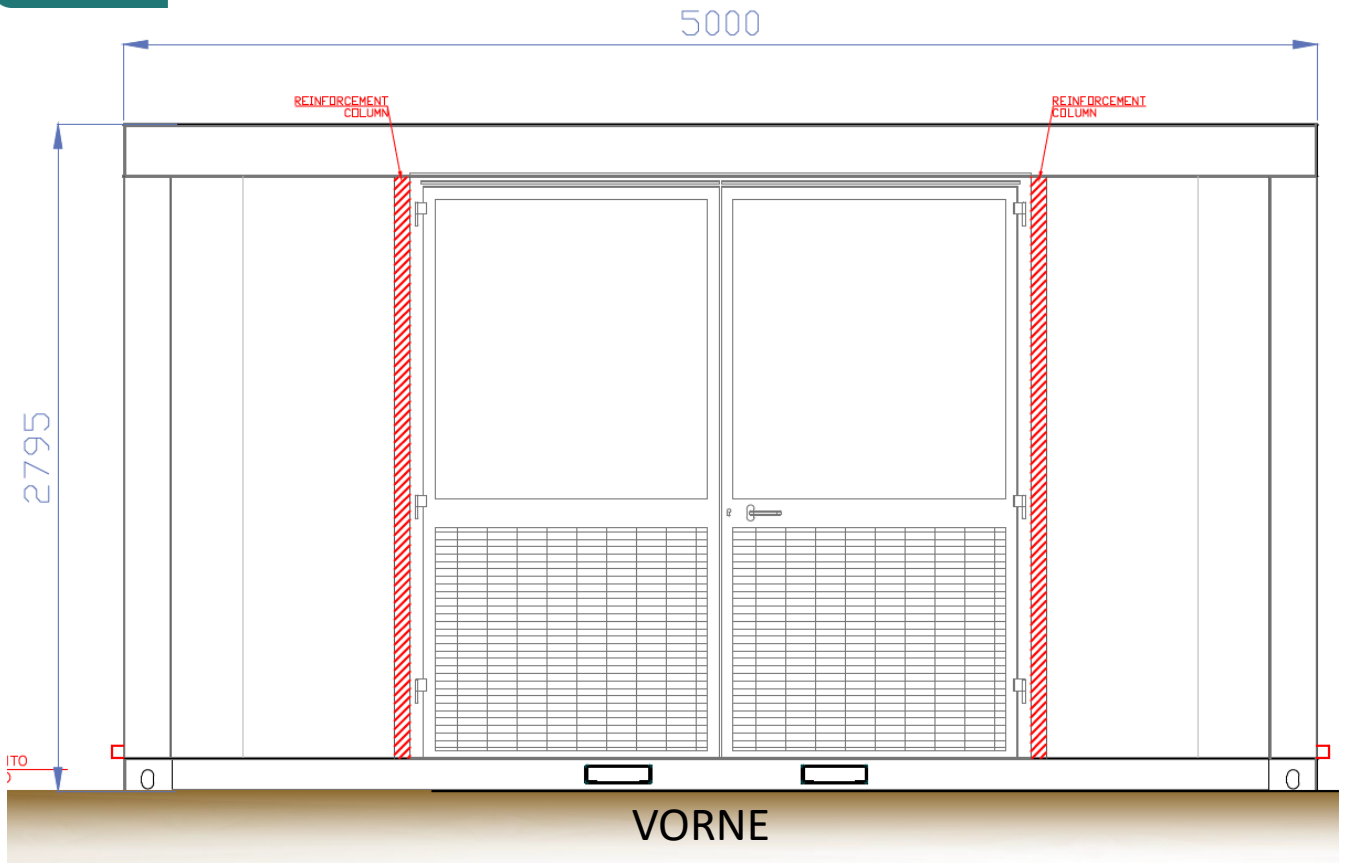

# E-Container Model- EXPO 5000

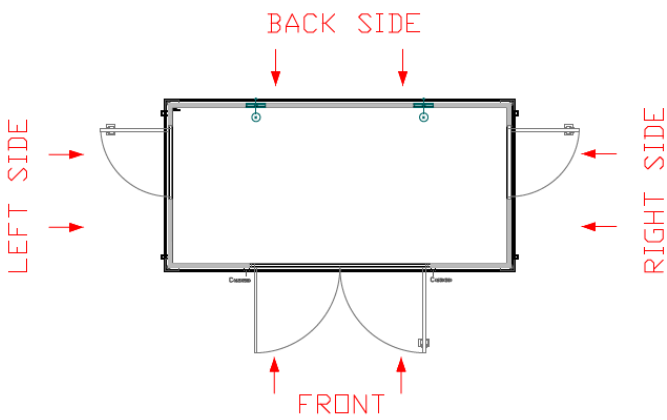
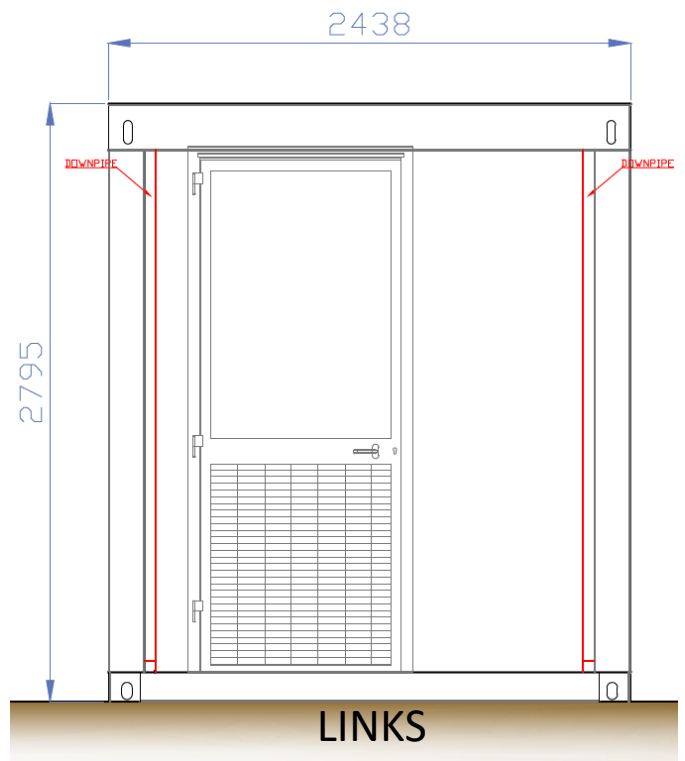
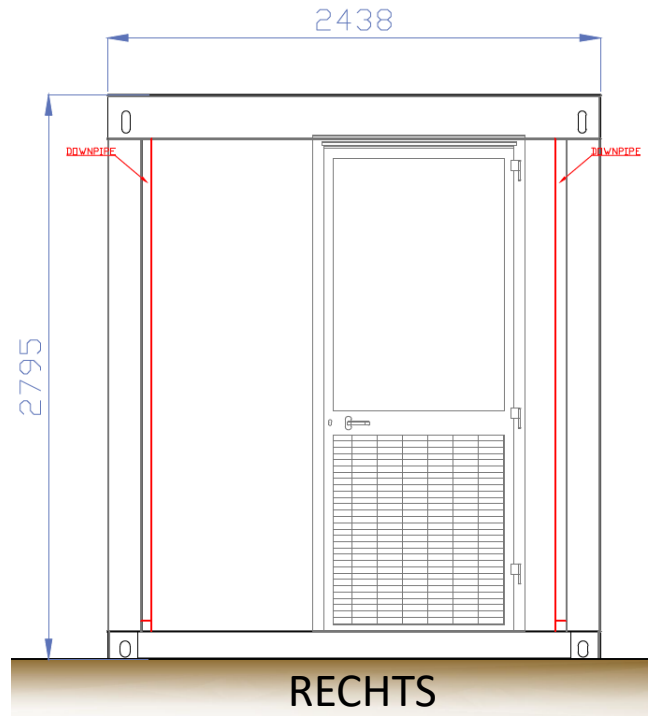
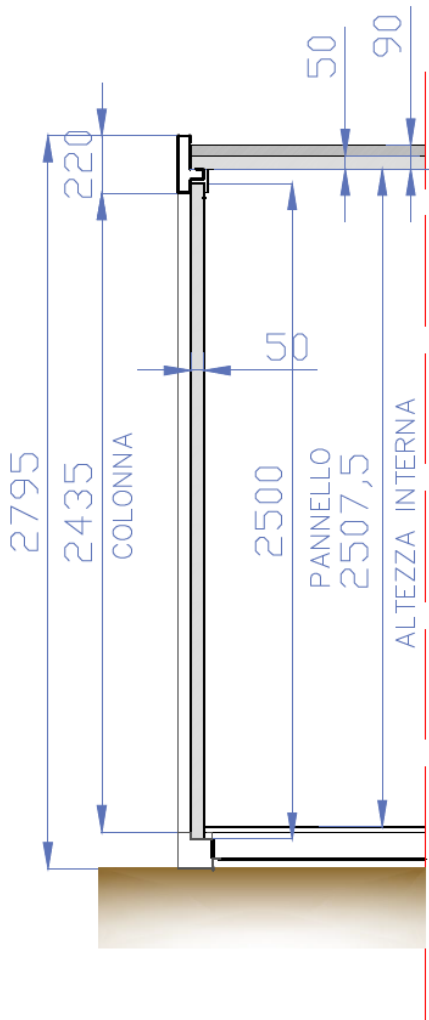

# E-Container Model- EXPO 5000

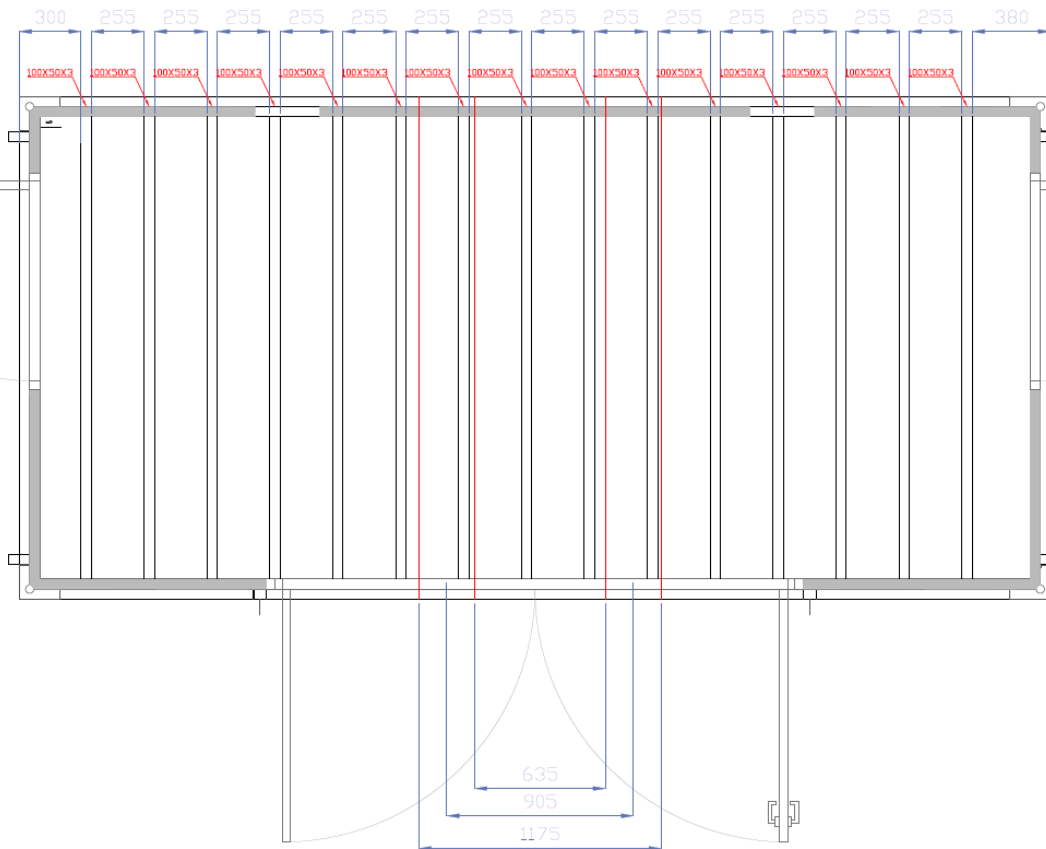
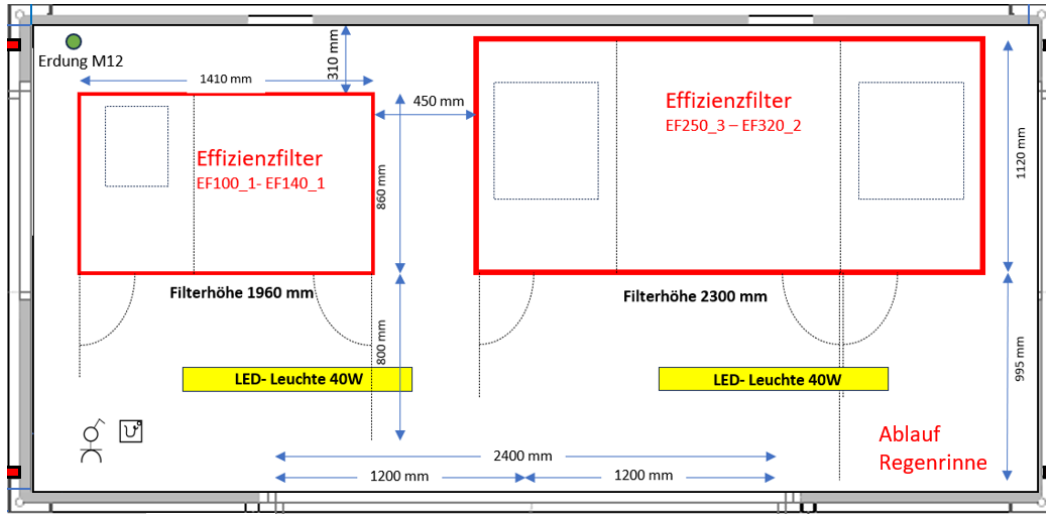

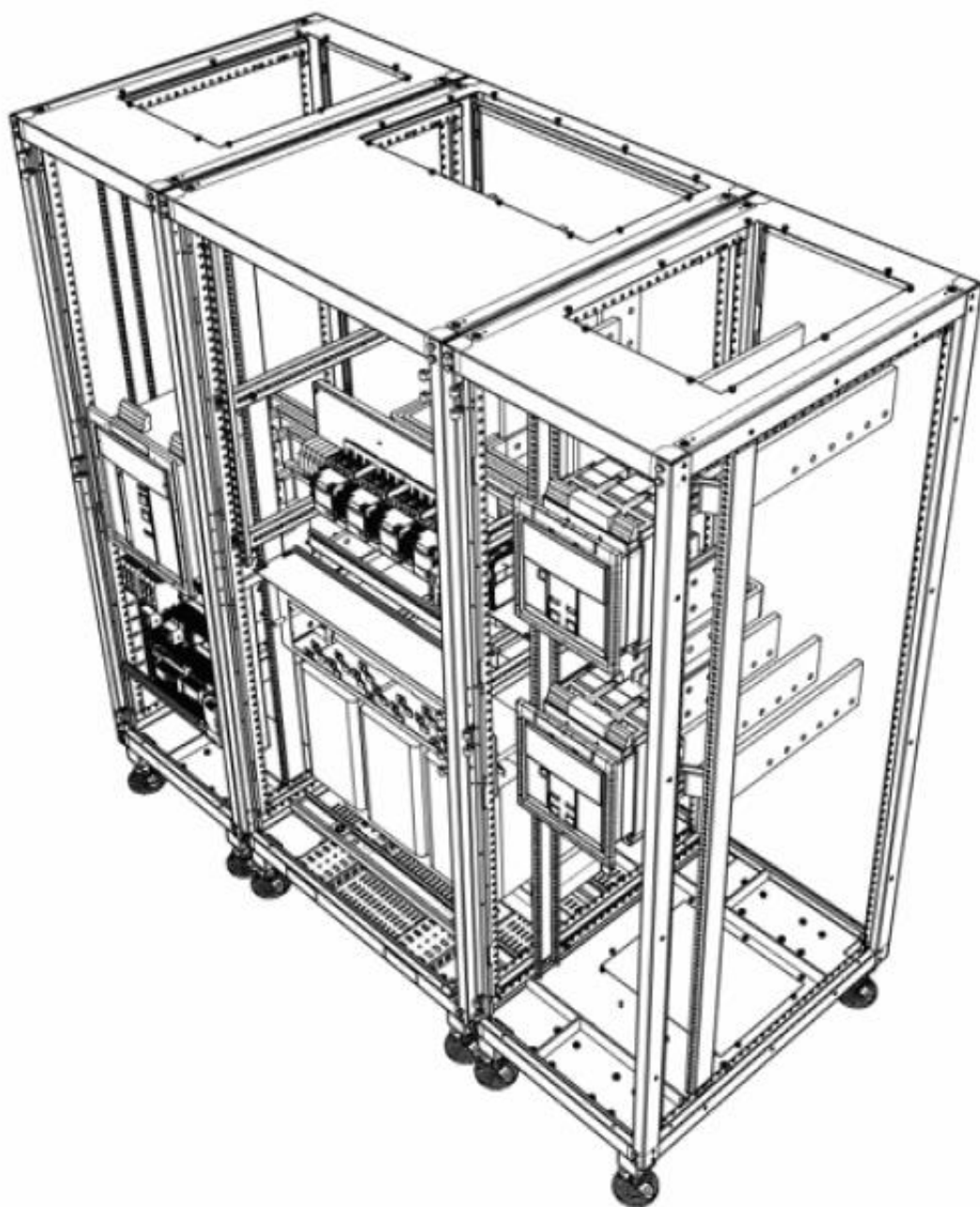

**LIVARSA AG**  
Tunnelstrasse 5  
(CH) 2540 Grenchen  
Tel. +41(0)32 517 95 05  
info@livarsa.ch

**www.LIVARSA.com**

**LIVARSA GmbH**  
Im Fruchtfeld 17  
(D) 77791 Berghaupten  
Tel. +49(0)7803 922 89 72  
info@livarsa.de

**Vertriebs- / Elektroinstallationspartner**

