

EFFIZIENZFILTER

mit zwei Leistungsschaltern

Typ:

EF100_L125_16_2

EF100_L160_16_2

EF125_L125_16_2

EF125_L160_16_2

EF125_L182_16_2

EF140_L160_16_2

EF140_L182_16_2

EF140_L200_16_2

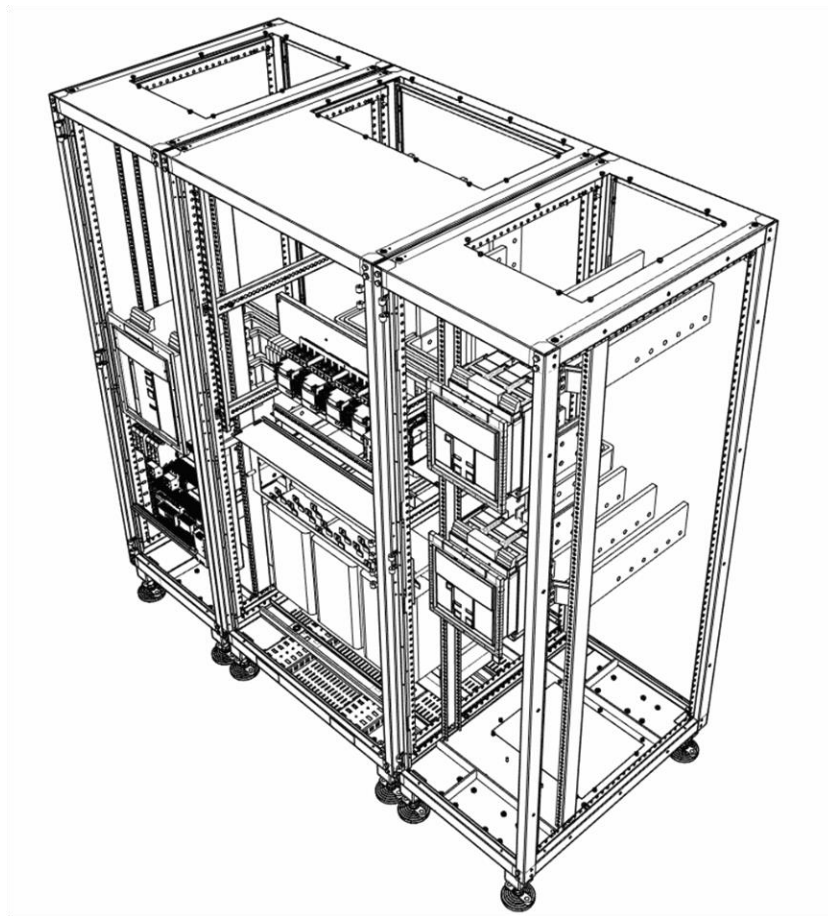

TECHNISCHE DATEN UND MASSBLATT

Leistungsebene **1000A-1600A**

Filter Belastung		
657 kW / 1000A	Bleibt der Filter zugeschaltet (Wirkung)	
690 kW / 1050A		
723 kW / 1100A		
736 kW / 1120A	4 Std 41 min	geht nach dieser Zeit in den BYPASS
749 kW / 1140A	1 Std 10 min	
763 kW / 1160A	31 min	
776 kW / 1180A	18 min	
789 kW / 1200A	11 min	
822 kW / 1250A	5 min	
855 kW / 1300A	3 min	
887 kW / 1350A	2 min	
920 kW / 1400A	1 min	
953 kW / 1450A	55 sec	
986 kW / 1500A	42 sec	
1019 kW / 1550A	33 sec	
1052 kW / 1600A	27 sec	

Leistungsebene **1250A-1850A**

Filter Belastung		
822 kW / 1250A	Bleibt der Filter zugeschaltet (Wirkung)	
855 kW / 1300A		
887 kW / 1350A		
901 kW / 1370A	7 Std 19 min	geht nach dieser Zeit in den BYPASS
914 kW / 1390A	1 Std 50 min	
927 kW / 1410A	49 min	
940 kW / 1430A	27 min	
953 kW / 1450A	18 min	
986 kW / 1500A	8 min	
1019 kW / 1550A	5 min	
1052 kW / 1600A	3 min	
1085 kW / 1650A	2 min	
1118 kW / 1700A	1 min 26 sec	
1150 kW / 1750A	1 min 6 sec	
1183 kW / 1800A	52 sec	
1216 kW / 1850A	42sec	

Leistungsebene **1400A-2000A**

Filter Belastung		
920 kW / 1400A	Bleibt der Filter zugeschaltet (Wirkung)	geht nach dieser Zeit in den BYPASS
953 kW / 1450A		
986 kW / 1500A		
999 kW / 1520A	9 Std 11 min	
1012 kW / 1540A	2 Std 17 min	
1026 kW / 1560A	1 Std 1 min	
1039 kW / 1580A	34 min	
1052 kW / 1600A	22 min	
1085 kW / 1650A	9 min	
1118 kW / 1700A	5 min	
1150 kW / 1750A	4 min	
1183 kW / 1800A	3 min	
1216 kW / 1850A	2 min	
1249 kW / 1900A	1 min 23 sec	
1282 kW / 1950A	1 min	
1315 kW / 2000A	53 sec	

ANZEIGEPANEL
NOT-BYPASSBEFEHL
BYPASSSCHALTER

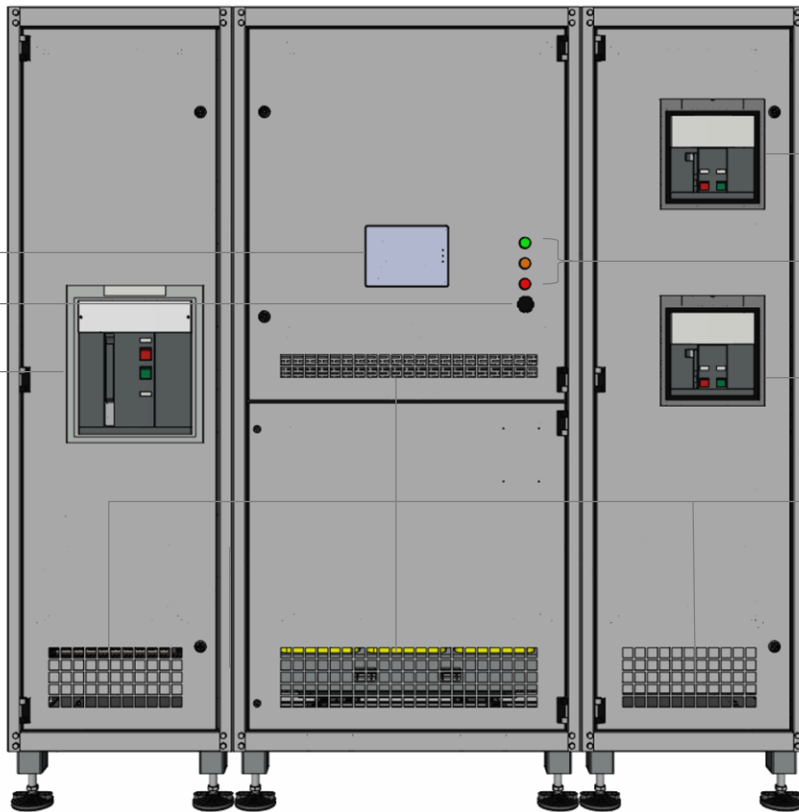

LEISTUNGSSCHALTER 1

STATUSMELDUNGEN

LEISTUNGSSCHALTER 2

LÜFTUNGSGITTER

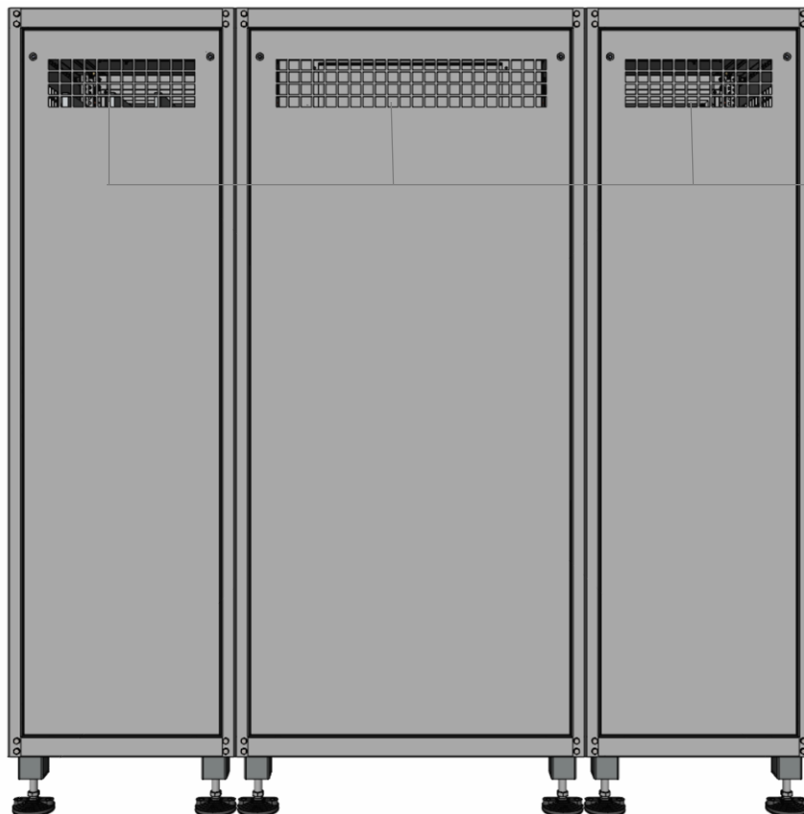

LÜFTUNGSGITTER

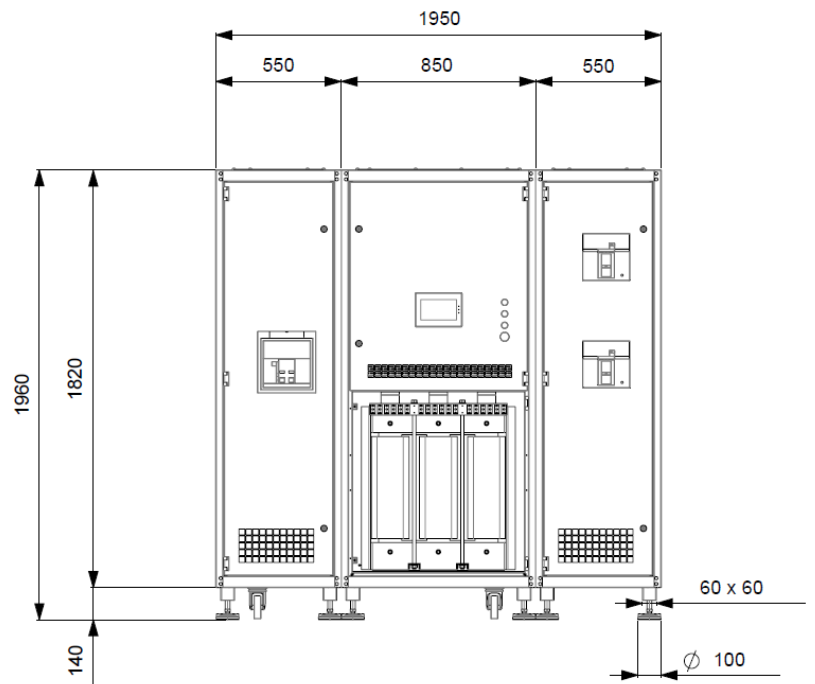
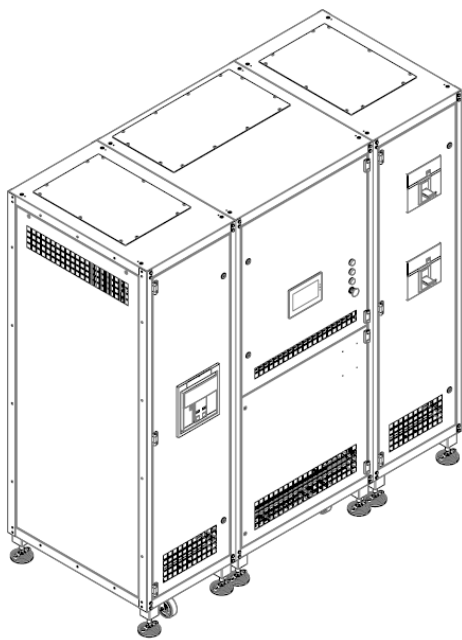
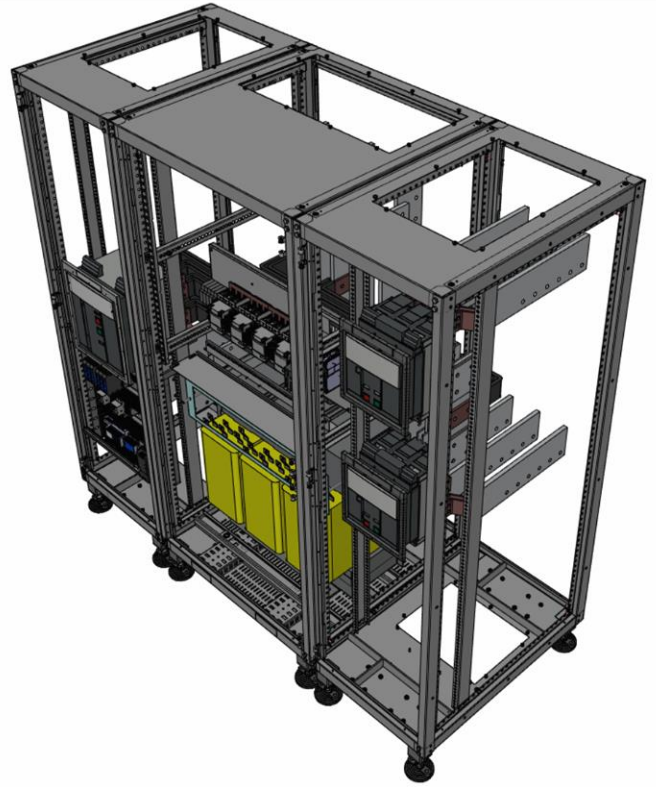

DATENLOGGER

SPS-STEUERUNG

BYPASSSCHALTER

MESSKLINIK

LEISTUNGSSCHALTER 1

STERNPUNKTSCHÜTZE

LEISTUNGSSCHALTER 2

FILTEREINHEIT

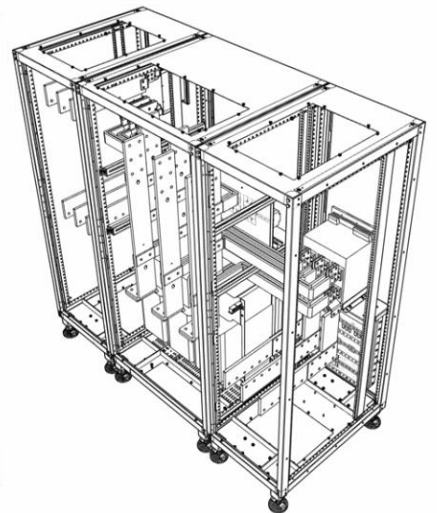
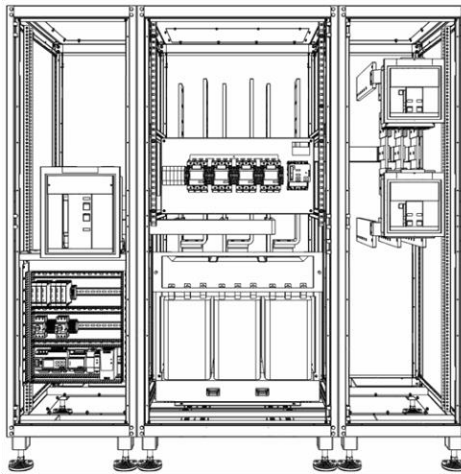
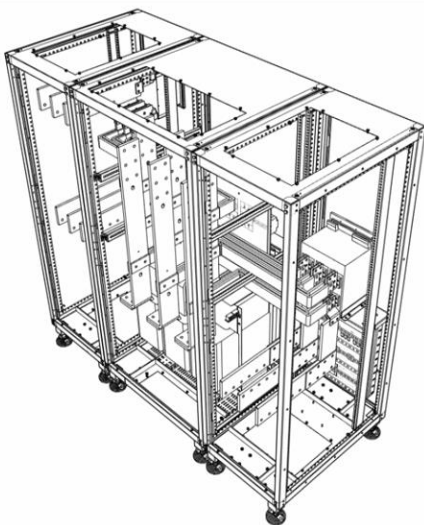

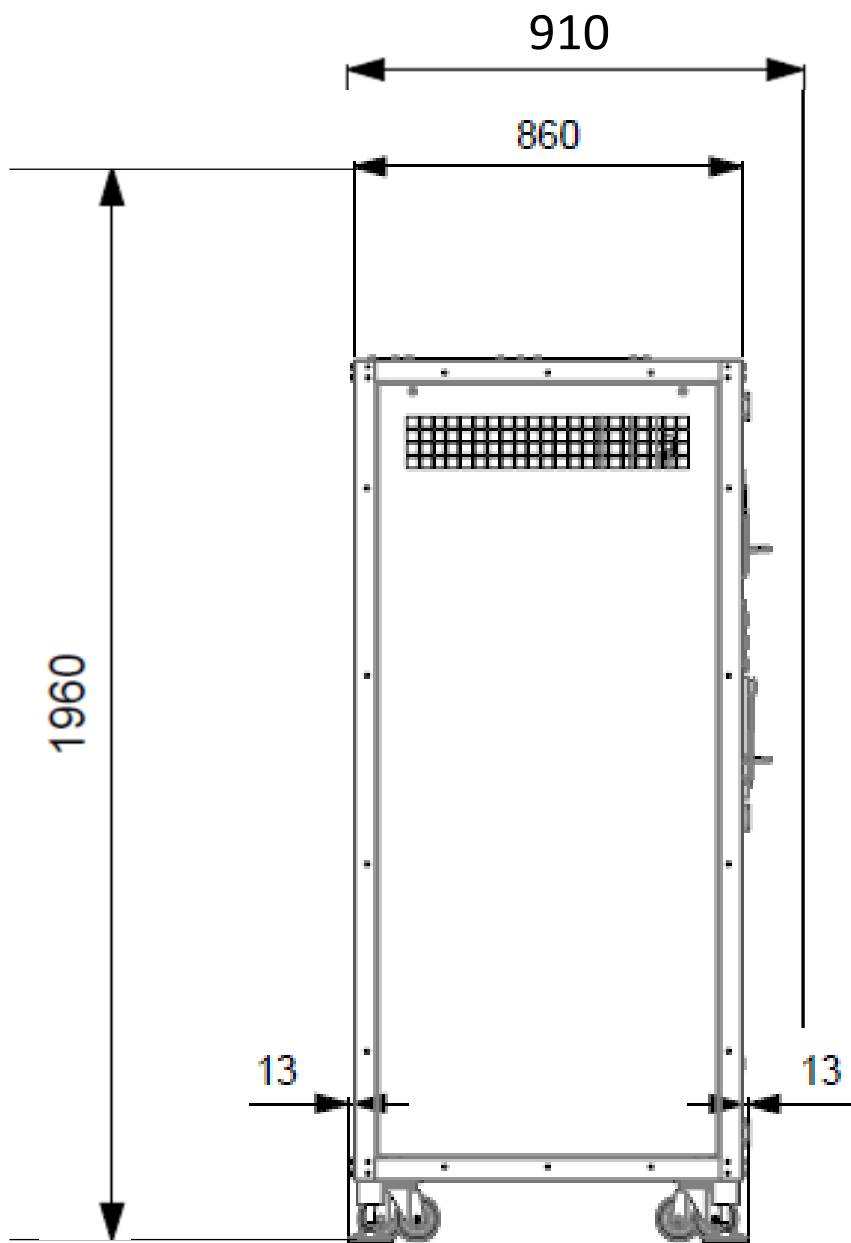

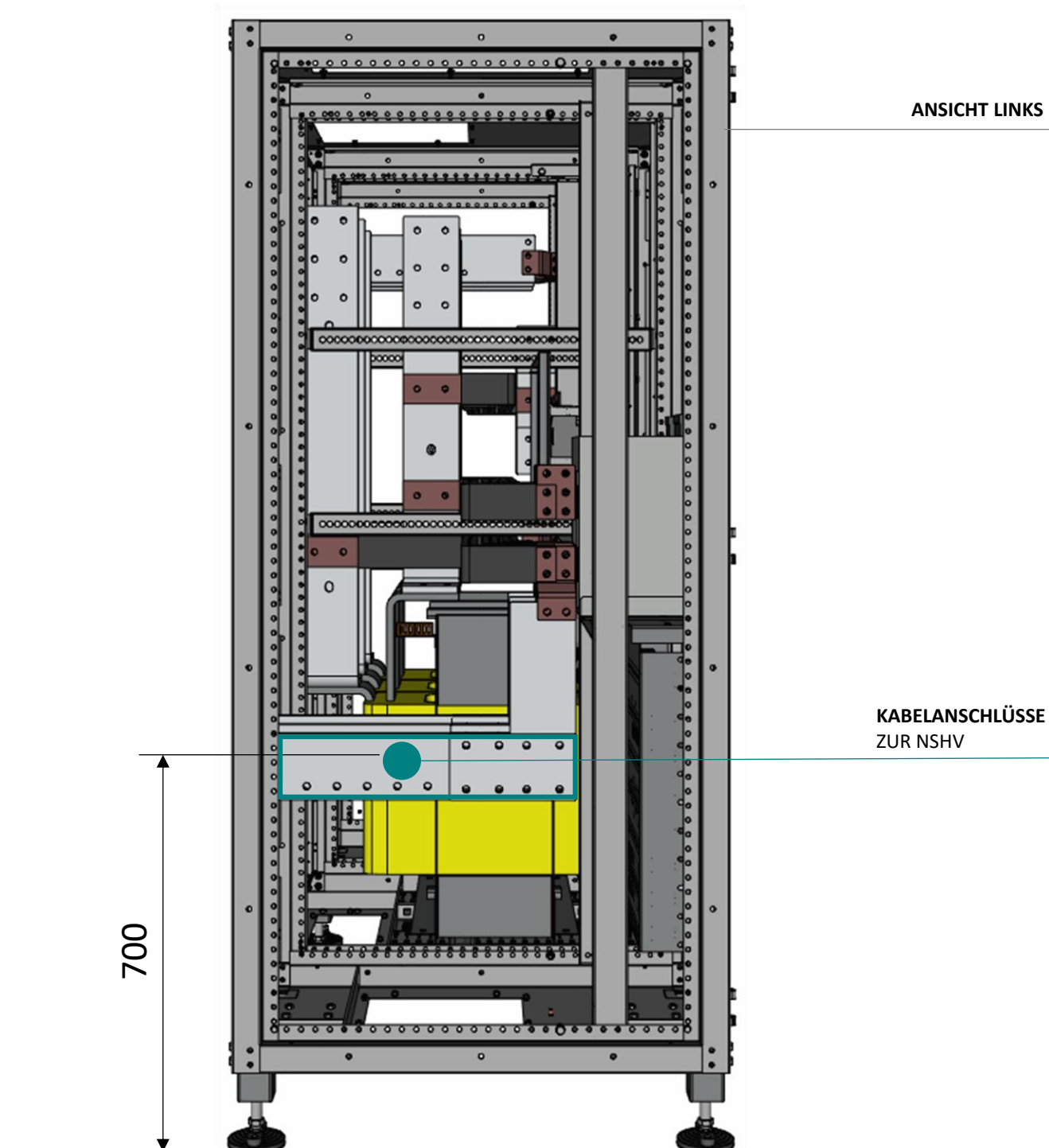

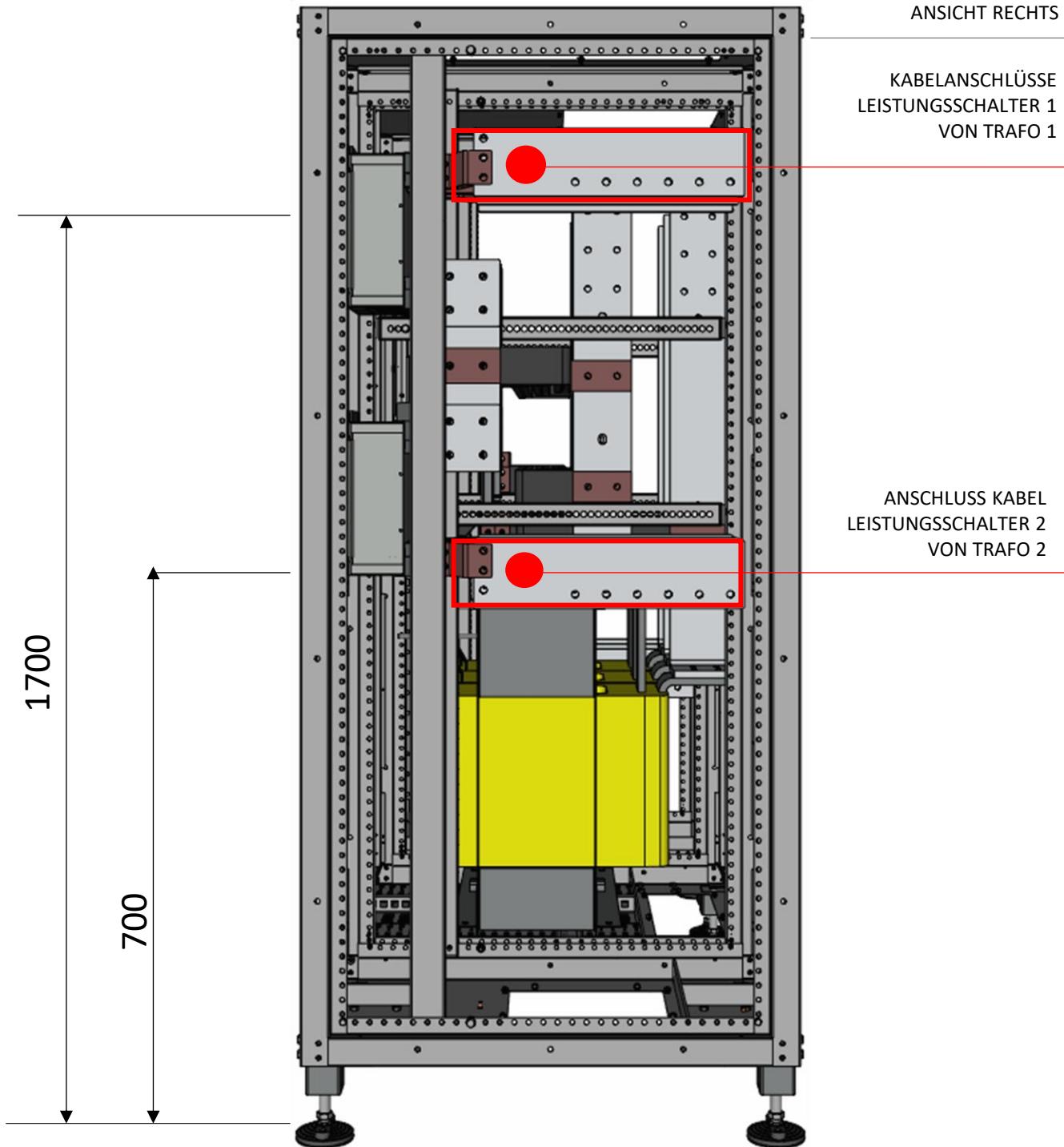

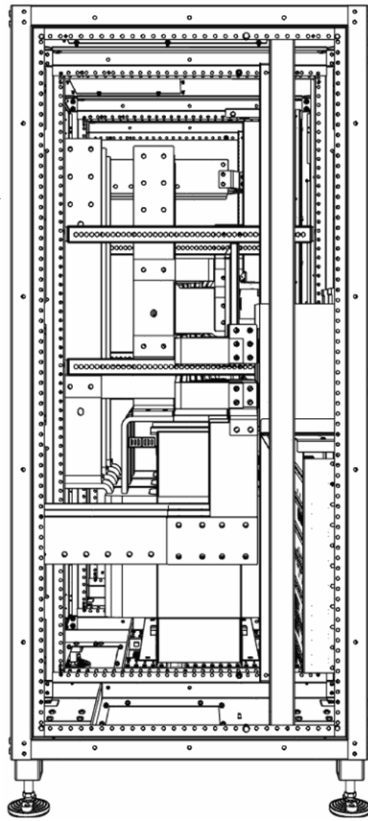
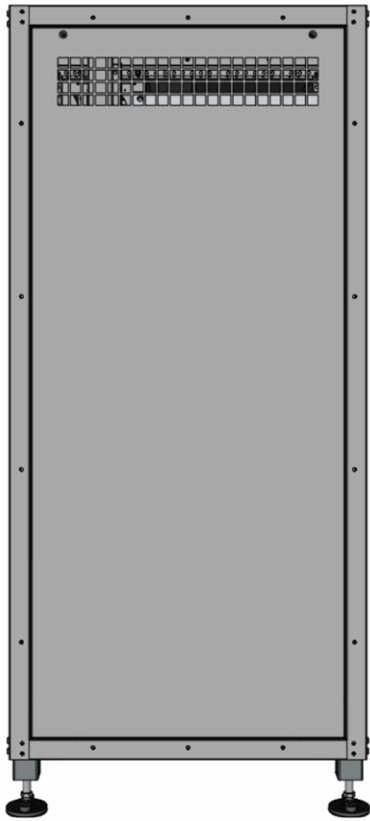

ANSICHT VON LINKS

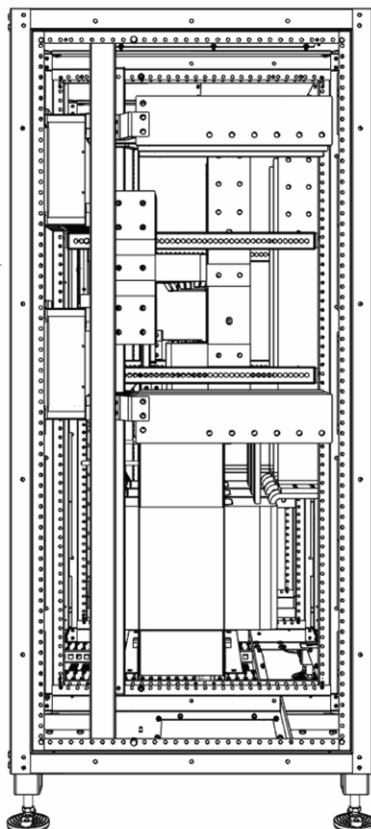
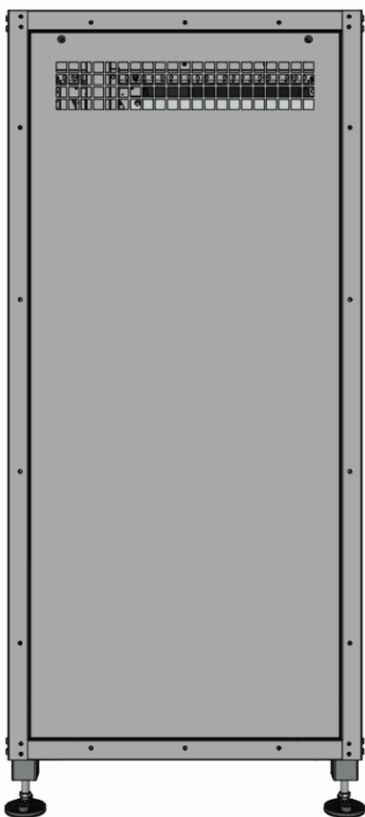

ANSICHT VON RECHTS

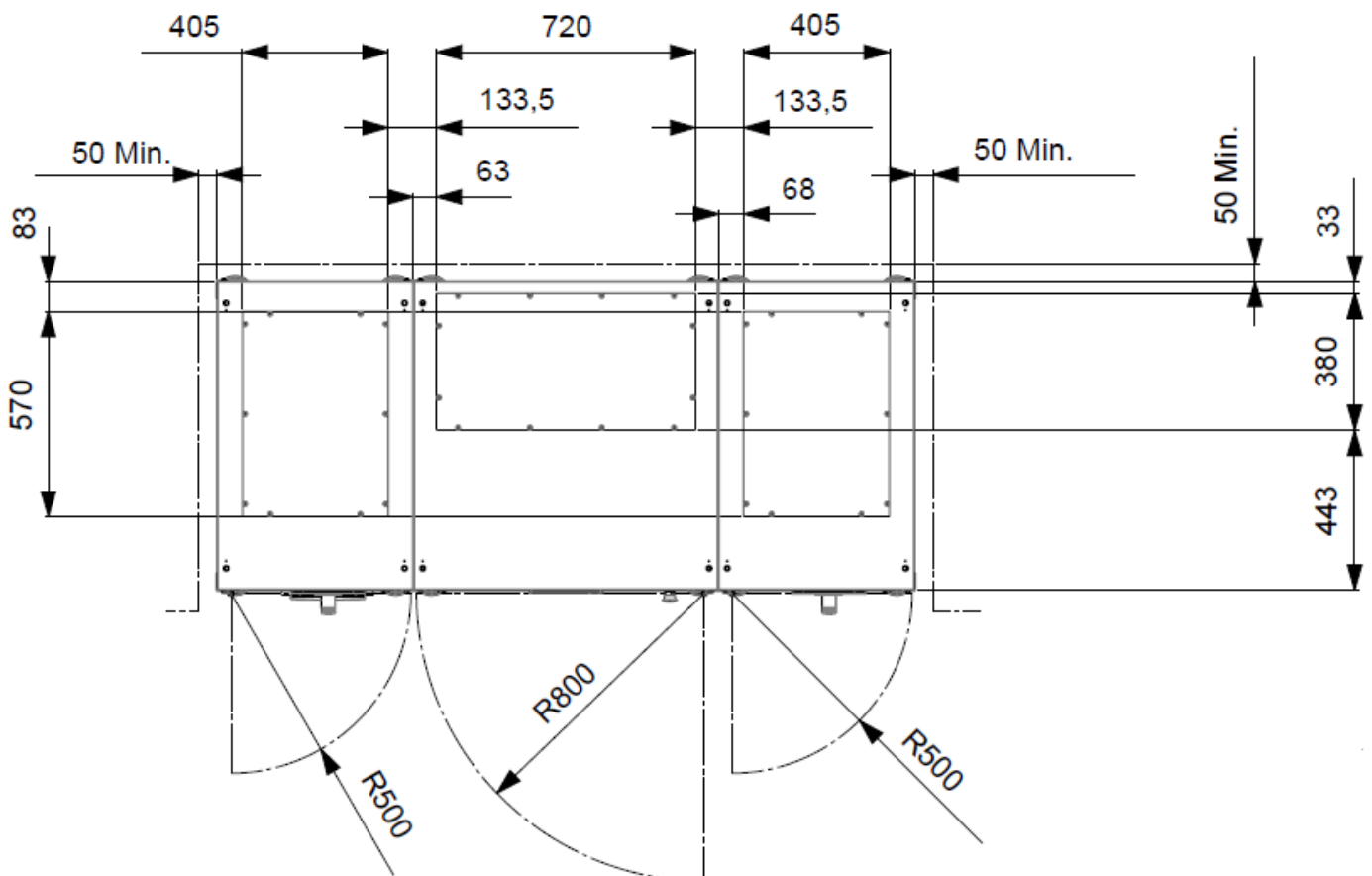
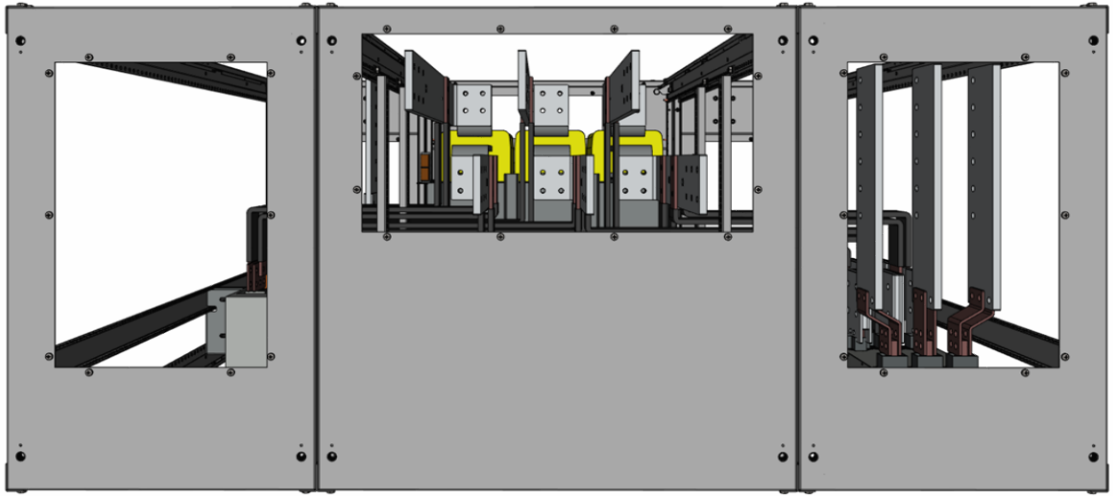

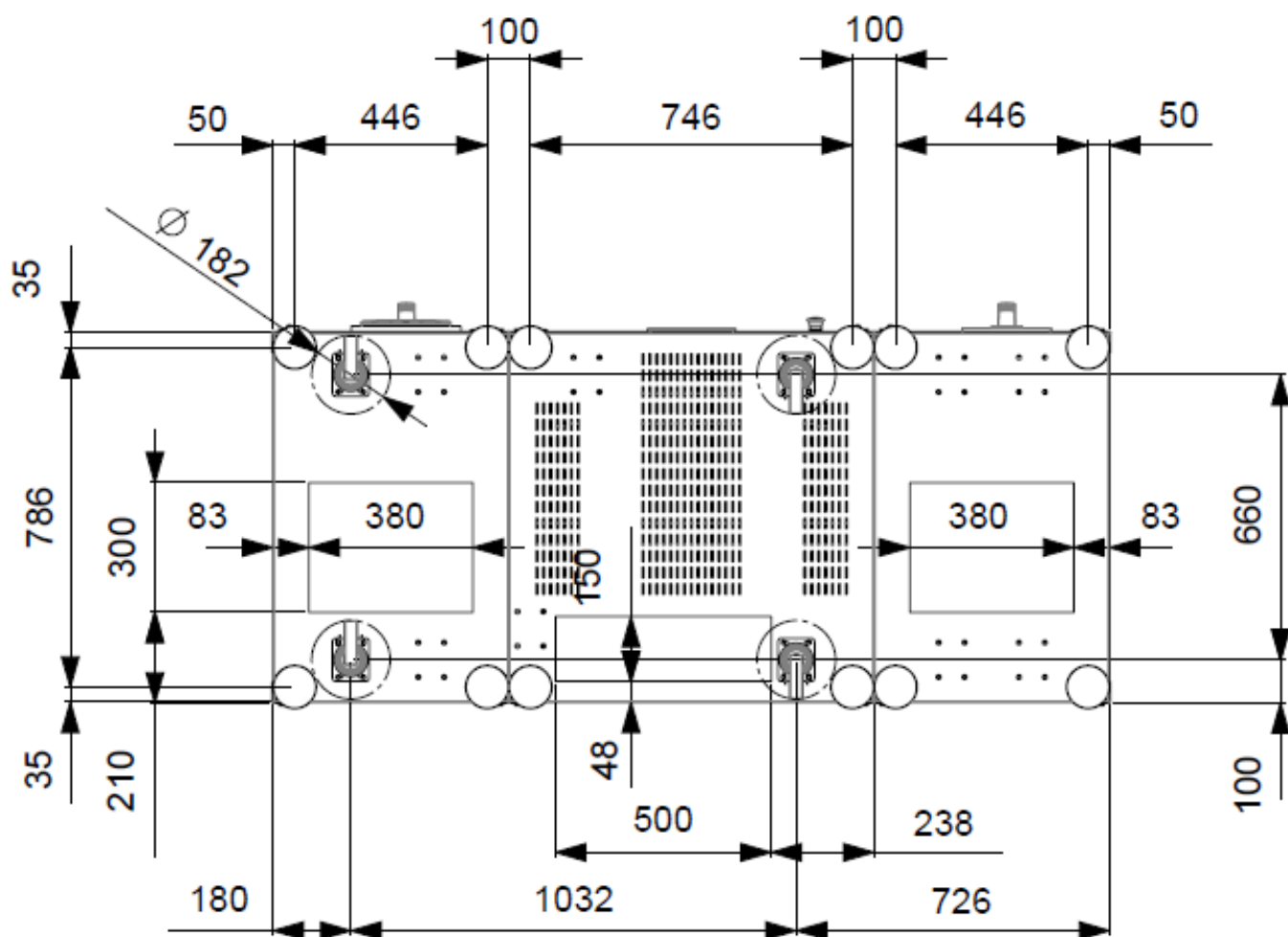
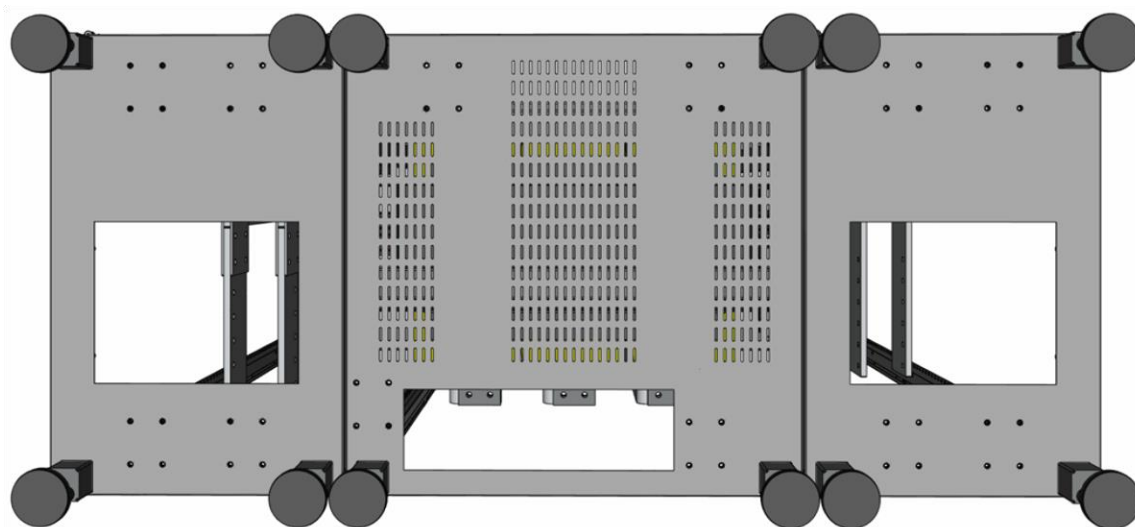

Mit 2 Leistungsschalter

Artikel-Nr	Filter	Leistungsschalter	Maße B/H/T	Gewicht	Icw Filter	Icu Schalter
EF100_L125_16_2	1000A	2 x LS 1600A	1950/1960/860 mm	1060 kg	50kA	50kA
EF100_L160_16_2	1000A	2 x LS 1600A	1950/1960/860 mm	1100 kg	50kA	50kA

Mit 2 Leistungsschalter

Artikel-Nr	Filter	Leistungsschalter	Maße B/H/T	Gewicht	Icw Filter	Icu Schalter
EF125_L125_16_2	1250A	2 x LS 1600A	1950/1960/860 mm	1180 kg	50kA	50kA
EF125_L160_16_2	1250A	2 x LS 1600A	1950/1960/860 mm	1220 kg	50kA	50kA
EF125_L182_16_2	1250A	2 x LS 1600A	1950/1890/860 mm	1260 kg	50kA	50kA

Mit 2 Leistungsschalter

Artikel-Nr.	Filter	Leistungsschalter	Maße B/H/T	Gewicht	Icw Filter	Icu Schalter
EF140_L160_16_2	1400A	2 x LS 1600A	1950/1960/860 mm	1300 kg	50kA	50kA
EF140_L182_16_2	1400A	2 x LS 1600A	1950/1960/860 mm	1340 kg	50kA	50kA
EF140_L200_16_2	1400A	2 x LS 1600A	1950/1960/860 mm	1380 kg	50kA	50kA

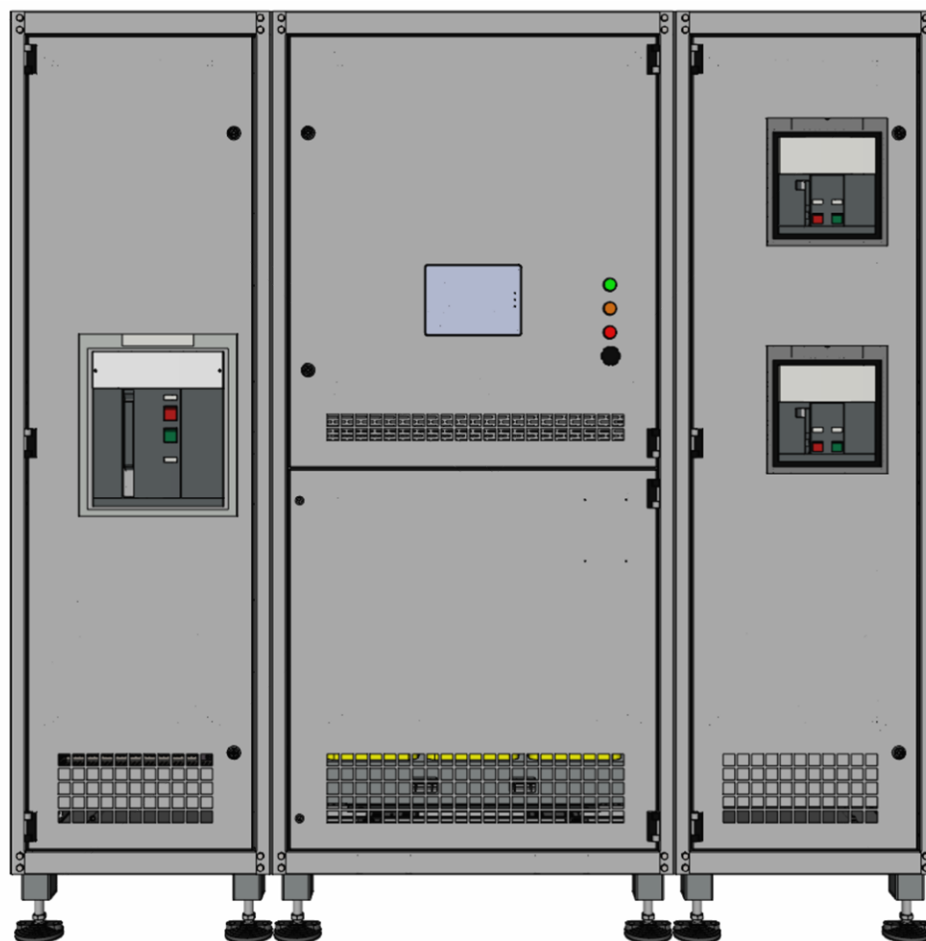

EINGANG VON UNTEN
LEISTUNGSSCHALTER 1

EINGANG VON UNTEN
LEISTUNGSSCHALTER 2

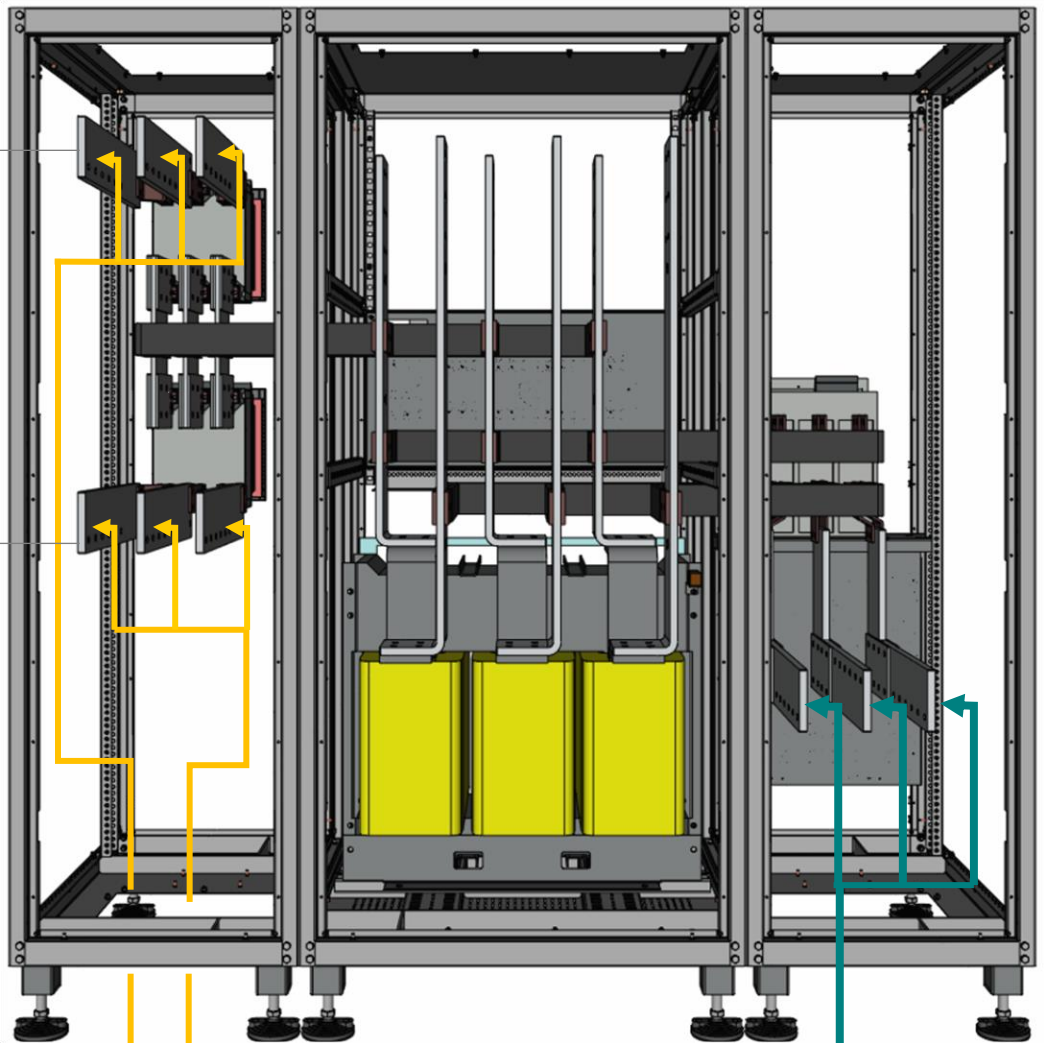

AUSGANG ZUR NSHV

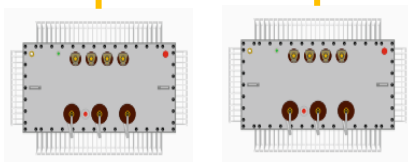

Nr.1

Nr.2

MITTELSPANNUNGSTRANSFORMATOREN



GEBÄUDE / HAUPTVERTEILUNG NSHV

ROUTER MIT SIM-KARTE Netzwerk Kunde

Mittelspannungstransformator
Messung Neutralleiter Überwachung

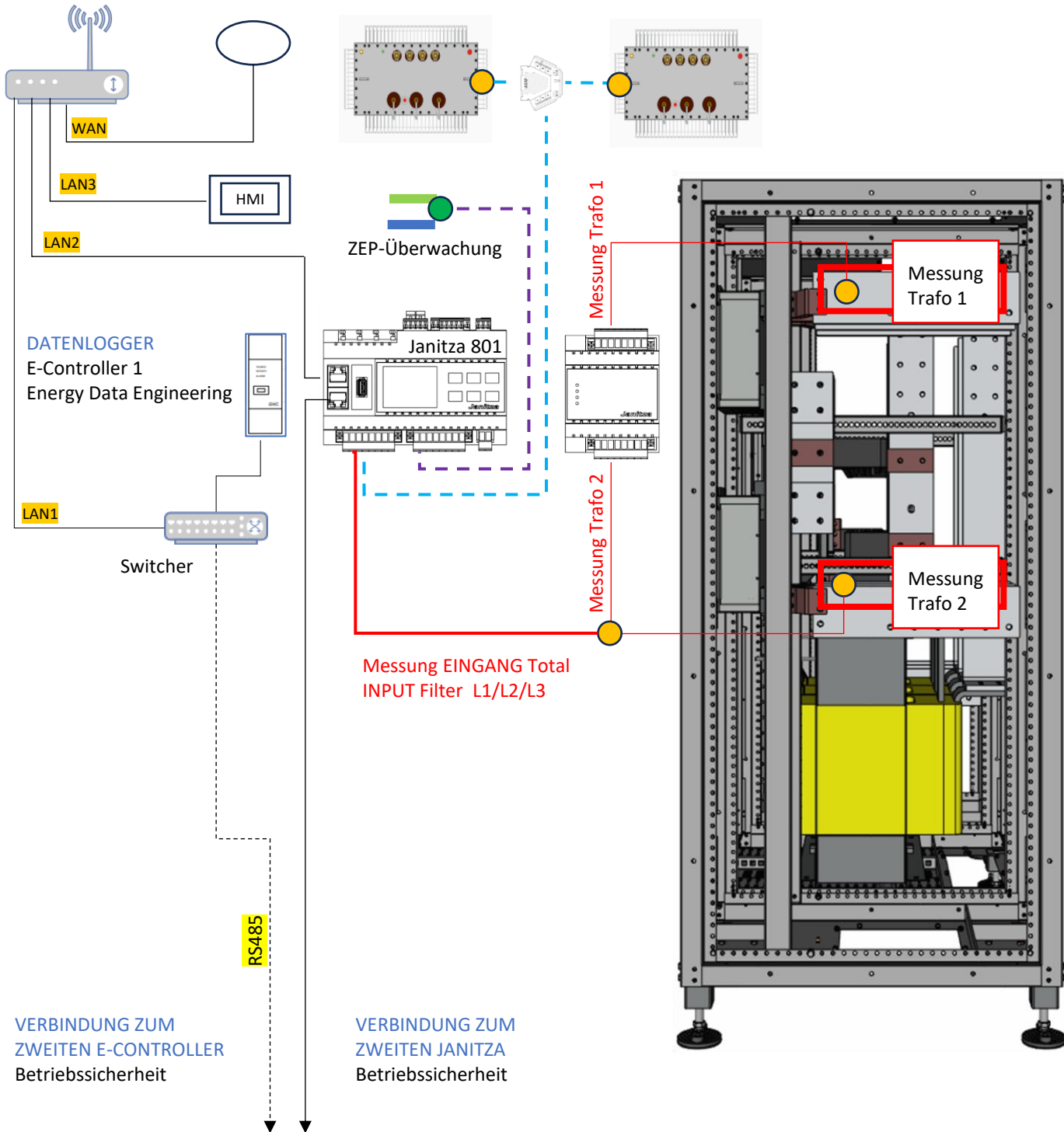

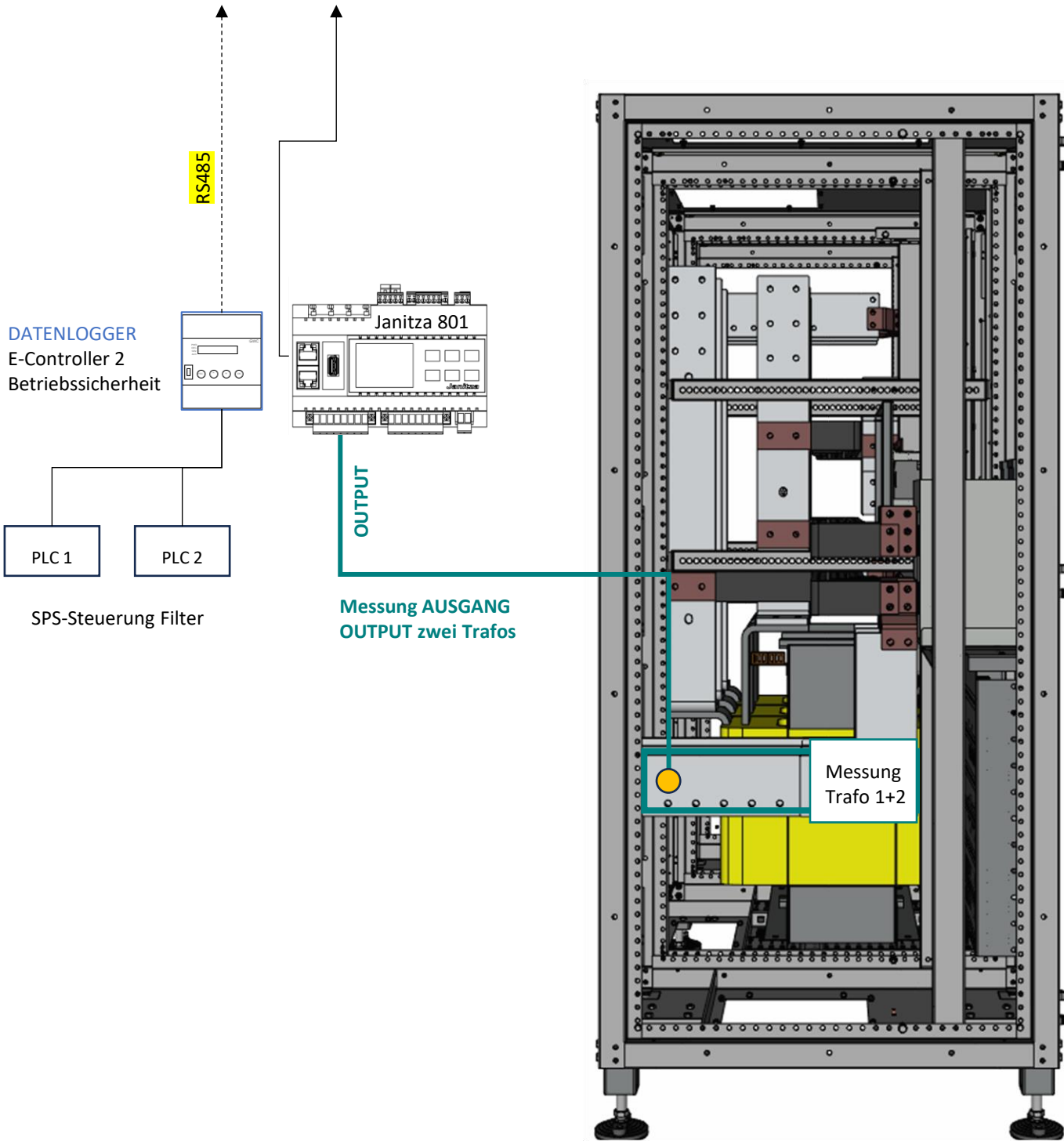

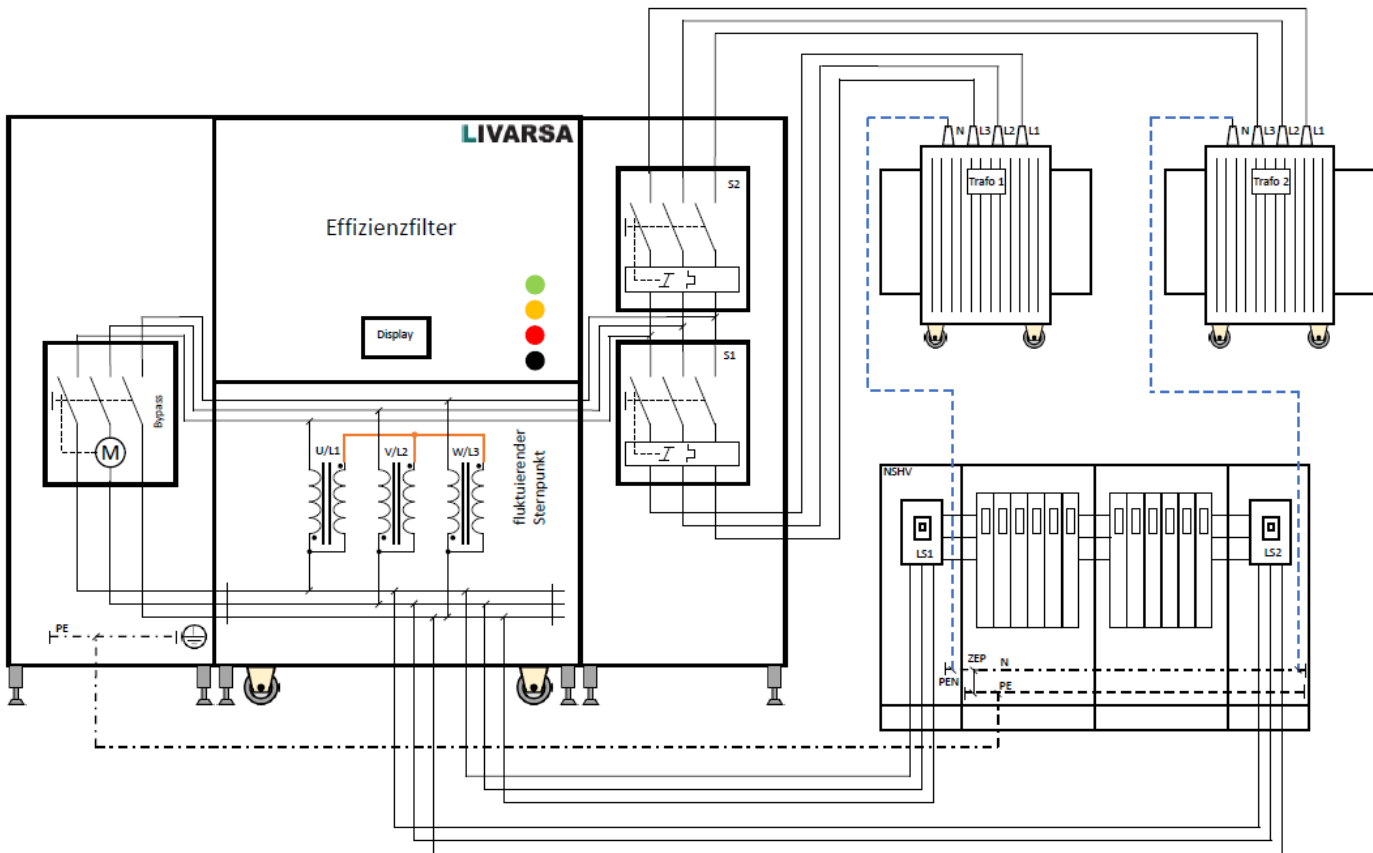

EINGANG FILTEREINHEIT

AUGANG FILTEREINHEIT

STEUERWICKLUNGEN 1-4

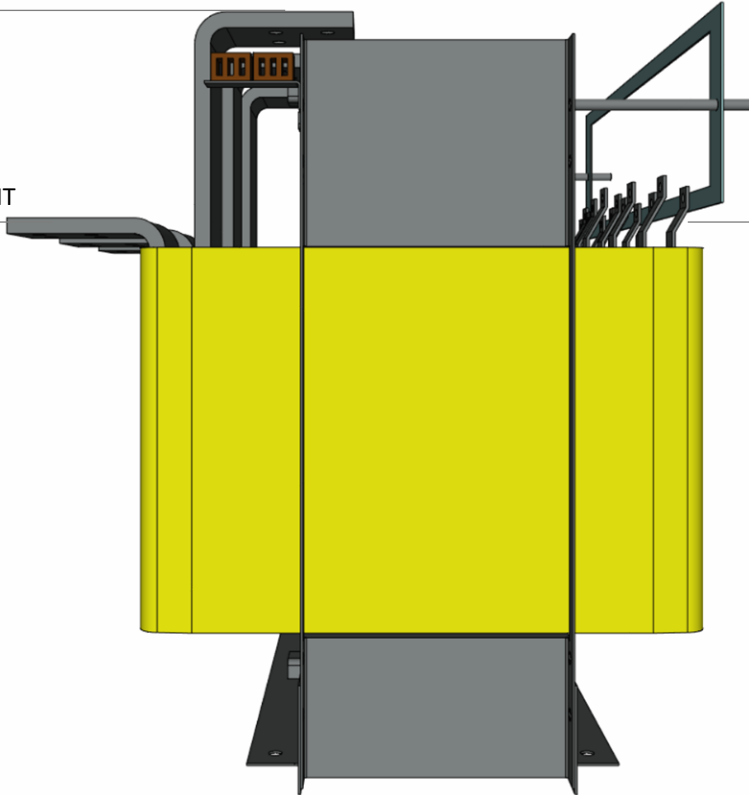

AUGANG FILTEREINHEIT

EINGANG FILTEREINHEIT

STEUERWICKLUNGEN 1-4

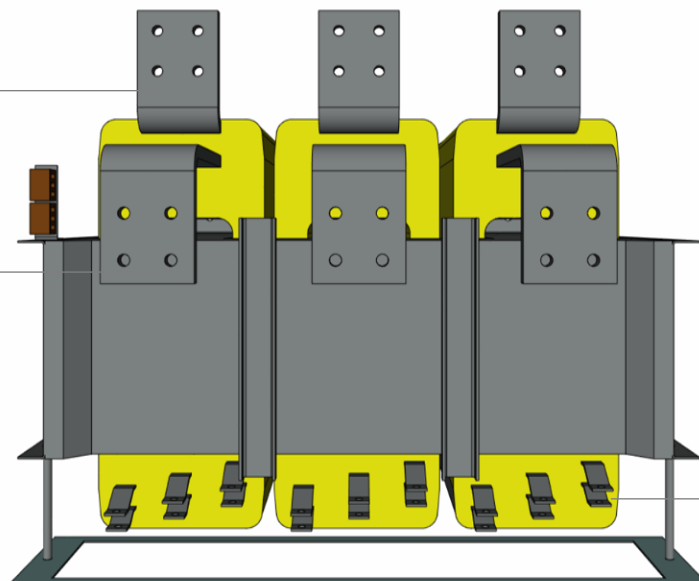

U

V

W

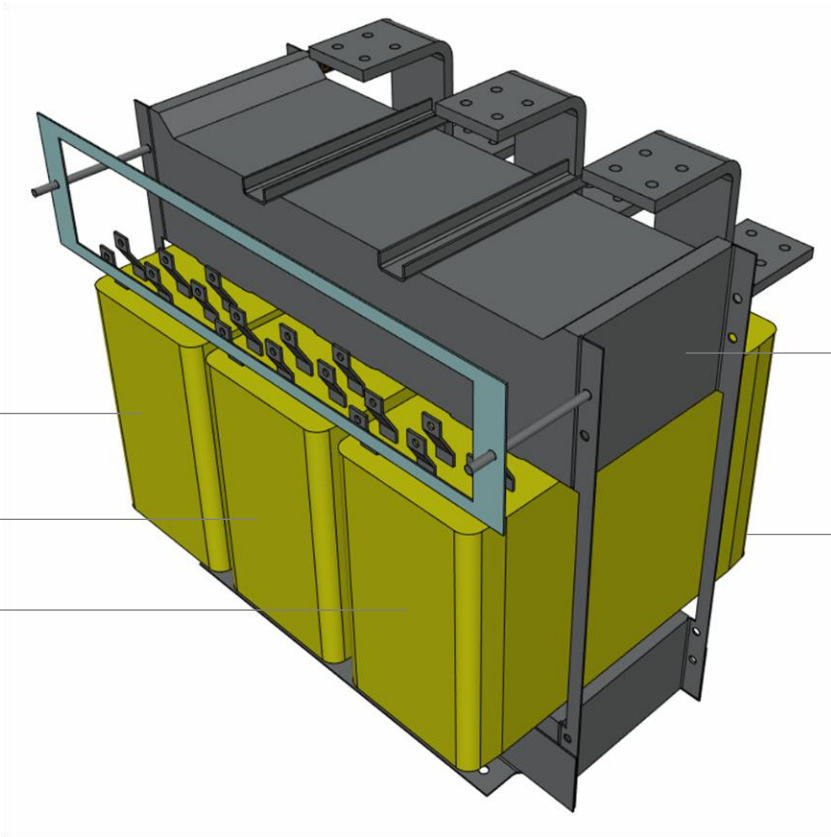

EISENKERN

ISOLIERPAPIER

ANSICHT VON OBEN

ANSICHT VON UNTEN

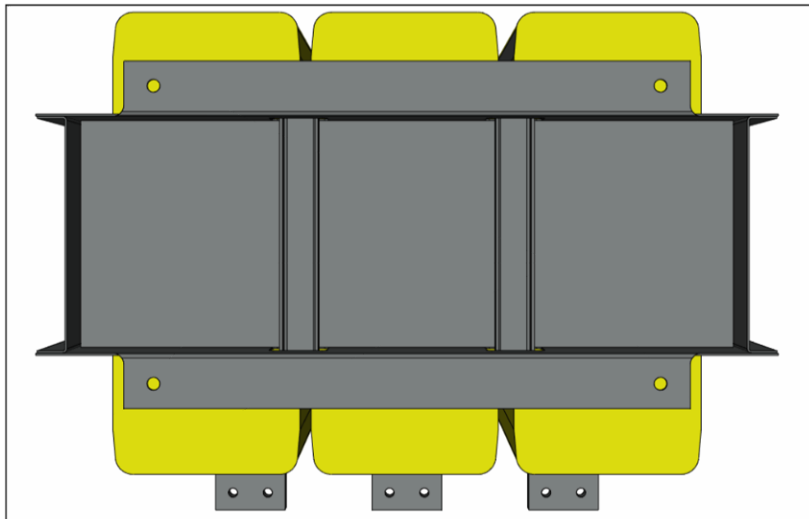
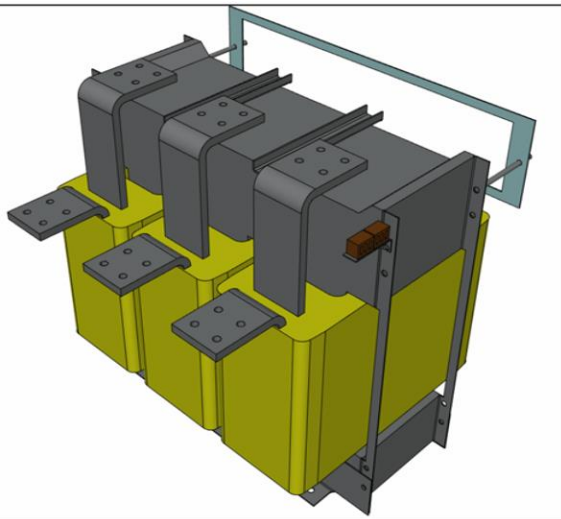

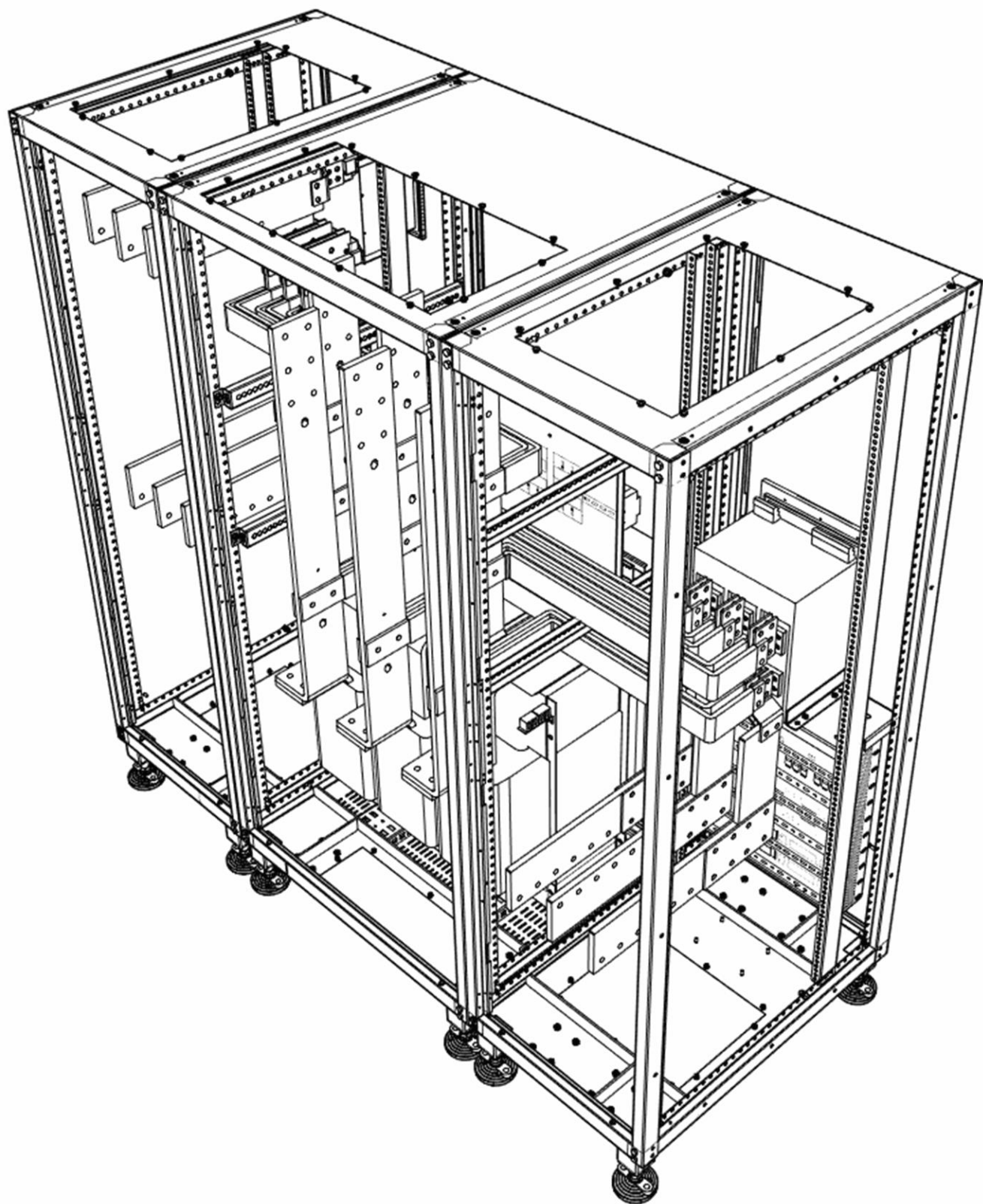

LIVARSA AG
Tunnelstrasse 5
(CH) 2540 Grenchen
Tel. +41(0)32 517 95 05
info@livarsa.ch

LIVARSA GmbH
Im Fruchtfeld 17
(D) 77791 Berghaupten
Tel. +49(0)7803 922 89 72
info@livarsa.de

Vertriebs- / Elektroinstallationspartner

www.LIVARSA.com